



IPSO - USA

OWNER'S MANUAL

75 lb. DR LAUNDRY DRYER

**Shown with manual double
timer control system**

Technical specifications

Installation instructions

Operating instructions

Maintenance

DR75

IPSO - USA

3101 South Haven Highway 77, Suite A

Panama City, FL, 32405

Phone: (850)271-8486

THIS MANUAL MUST BE GIVEN TO THE EQUIPMENT OWNER

IMPORTANT NOTICES—PLEASE READ

For optimum efficiency and safety, we recommend that you read the Manual before operating the equipment. Store this manual in a file or binder and keep for future reference.



WARNING: For your safety, the information in this manual must be followed to minimize the risk of fire or explosion or to prevent property damage, personal injury, or loss of life.

- Do not store or use gasoline or other flammable liquids or vapors in the vicinity of this or any other appliance.
- **WHAT TO DO IF YOU SMELL GAS**
 - Do not try to light any appliances.
 - Do not touch any electrical switch; do not use any phone in your building.
 - Clear the room, building, or area of all occupants.
 - Immediately call your gas supplier from a neighbor's phone. Follow the gas supplier's instructions.
 - If you cannot reach the gas supplier, call the fire department.

Installation and service must be performed by a qualified installer, service agency or the gas supplier.



WARNING: In the event the user smells gas odor, instructions on what to do must be posted in a prominent location. This information can be obtained from the local gas supplier.



WARNING: Wear Safety Shoes to prevent injuries.



WARNING: Purchaser must post the following notice in a prominent location:



FOR YOUR SAFETY

Do not store or use gasoline or other flammable vapors and liquids in the vicinity of this or any other appliance.



WARNING: A clothes dryer produces combustible lint and should be exhausted outside the building. The dryer and the area around the dryer should be kept free of lint.



WARNING: Be safe, before servicing machine, the main power should be shut off.

**ATTENTION: L'ACHETEUR DOIT PLACER L'AVERTISSEMENT
SUIVANT DANS UN ENDROIT CLAIR ET VISIBLE:**

AVERTISSEMENT. Assurez-vous de bien suivre les instructions donnees dans cette notice pour reduire au minimum le risque d'incendie ou d'explosion ou pour eviter tuot dommage materiel, toute blessure ou la mort.

__ Ne pas entreposer ni utiliser d'essence ni d'autres vapeurs ou liquides inflammables dans le voisinage de cet appareil ou de tout autre appareil.

__ **QUE FAIRE SI VOUS SENTEZ UNE ODEUR DE GAZ:**

- Ne pas tenter d'allumer d'appareil.
- Ne touchez a aucun interrupteur. Ne pas vous servir des telephones se trouvant dans le batiment ou vous vous trouvez.
- Evacuez la piece, le batiment ou la zone.
- Appelez immediatement votre fournisseur de gaz depuis un voisin. Suivez les instructions du fournisseur.
- Si vous ne pouvez rejoindre le fournisseur de gaz, appelez le service des incendies.

__ l'installation et l'entretien doivent etre assures par un installateur ou un service d'entretien qualifie ou par le fournisseur de gaz.

**ATTENTION: L'ACHETEUR DOIT PLACER L'AVERTISSEMENT
SUIVANT DANS UN ENDROIT CLAIR ET VISIBLE:**

POUR VOTRE SECURITE

Ne pas entreposer ni utiliser d' essence ni d'autres vapeurs ou liquides inflammables dans le voisinage de cet appareil ou de tout autre appareil.



WARNING: To avoid fire hazard, do not dry articles containing foam rubber or similar texture materials. Do not put into this dryer flammable items such as baby bed mattresses, throw rugs, undergarments (brassieres, etc.) and other items which use rubber as padding or backing. Rubber easily oxidizes causing excessive heat and possible fire. These items should be air dried.



WARNING: Synthetic solvent fumes from drycleaning machines create acids when drawn through the dryer. These fumes cause rusting of painted parts, pitting of bright or plated parts, and completely removes the zinc from galvanized parts, such as the tumbler basket. If drycleaning machines are in the same area as the tumbler, the tumbler's make-up air must come from a source free of solvent fumes.



WARNING: Do not operate without guards in place.



WARNING: Check the lint trap often and clean as needed but at least a minimum of once per day.



WARNING: Alterations to equipment may not be carried out without consulting with the factory and only by a qualified engineer or technician. Only **Manufacturer's** parts may be used.



WARNING: Remove clothes from dryer as soon as it stops. This keeps wrinkles from setting in and reduces the possibility of spontaneous combustion.



WARNING: Be Safe - shut main electrical power and gas supply off externally before attempting service.



WARNING: Never use drycleaning solvents, gasoline, kerosene, or other flammable liquids in the dryer. ***FIRE AND EXPLOSION WILL OCCUR. NEVER PUT FABRICS TREATED WITH THESE LIQUIDS INTO THE DRYER. NEVER USE THESE LIQUIDS NEAR THE DRYER..***



WARNING: Do not place items exposed to cooking oils in your dryer. Items contaminated with cooking oils may contribute to a chemical reaction that could cause a load to catch fire.



WARNING: Never let children play near or operate the dryer. Serious injury could occur if a child should crawl inside and the dryer is turned on.



WARNING: Never tumble fiberglass materials in the dryer unless the labels say they are machine dryable. Glass fibers break and can remain in the dryer. These fibers cause skin irritation if they become mixed with other fabrics.



WARNING: Before operating gas ignition system - purge air from natural gas or propane gas lines per manufacturer's instructions.



WARNING: To reduce the risk of electric shock, disconnect this appliance from the power supply before attempting any user maintenance other than cleaning the lint trap. Turning the controls to the OFF position does not disconnect this appliance from the power supply.

IPSO DRYER WARRANTY

IPSO warrants all new equipment (and the original parts thereof) to be free from defects in material or workmanship for a period of two (2) years from the date of sale thereof to an original purchaser for use, except as hereinafter provided. With respect to non-durable parts normally requiring replacement in less than two (2) years due to normal wear and tear, and with respect to all new repair or replacement parts for IPSO equipment for which the two (2) year warranty period has expired, or for all new repair or replacement parts for equipment other than IPSO equipment, the warranty period is limited to ninety (90) days from date of sale. The warranty period on each new replacement part furnished by IPSO in fulfillment of the warranty on new equipment or parts shall be for the unexpired portion of the original warranty period on the part replaced.

With respect to electric motors, coin meters and other accessories furnished with the new equipment, but not manufactured by IPSO, the warranty is limited to that provided by the respective manufacturer.

IPSO's total liability arising out of the manufacture and sale of new equipment and parts, whether under the warranty or caused by IPSO's negligence or otherwise, shall be limited to IPSO-USA repairing or replacing, at its option, any defective equipment or part returned f.o.b. IPSO's factory, transportation prepaid, within the applicable warranty period and found by IPSO to have been defective, and in no event shall IPSO be liable for damages of any kind, whether for any injury to persons or property or for any special or consequential damages. The liability of IPSO does not include furnishing (or paying for) any labor such as that required to service, remove or install; to diagnose troubles; to adjust, remove or replace defective equipment or a part; nor does it include any responsibility for transportation expense which is involved therein.

The warranty of IPSO is contingent upon installation and use of its equipment under normal operating conditions. The warranty is void on equipment or parts; that have been subjected to misuse, accident, or negligent damage; operated under loads, pressures, speeds, electrical connections, plumbing, or conditions other than those specified by IPSO; operated or repaired with other than genuine IPSO replacement parts; damaged by fire, flood, vandalism, or such other causes beyond the control of IPSO; altered or repaired in any way that effects the reliability or detracts from its performance, or; which have had the identification plate, or serial number, altered, defaced, or removed.

No defective equipment or part may be returned to IPSO for repair or replacement without prior written authorization from IPSO. Charges for unauthorized repairs will not be accepted or paid by IPSO.

IPSO MAKES NO OTHER EXPRESSED OR IMPLIED WARRANTY, STATUTORY OR OTHERWISE, CONCERNING THE EQUIPMENT OR PARTS INCLUDING, WITHOUT LIMITATION, A WARRANTY OF FITNESS FOR A PARTICULAR PURPOSE, OR A WARRANTY OF MERCHANTABILITY. THE WARRANTIES GIVEN ABOVE ARE EXPRESSLY IN LIEU OF ALL OTHER WARRANTIES, EXPRESSED OR IMPLIED. IPSO NEITHER ASSUMES, NOR AUTHORIZES ANY PERSON TO ASSUME FOR IT, ANY OTHER WARRANTY OR LIABILITY IN CONNECTION WITH THE MANUFACTURE, USE OR SALE OF ITS EQUIPMENT OR PARTS.

For warranty service, contact the distributor from whom the IPSO equipment or part was purchased. If the distributor cannot be reached, contact IPSO.

IDENTIFICATION NAMEPLATE

The identification nameplate is located on the rear wall of the dryer. It contains the dryer serial number, product number, model number, electrical specifications and other important data that may be needed when servicing and ordering parts, wiring diagrams, etc. Do not remove this nameplate.













Contents

| | |
|---|-------|
| Safety Instructions | 2-4 |
| Cissell Dryer Warranty | 5 |
| Table of Contents | 6 |
| Symbols | 7 |
| Unpacking / General Installation | 8-9 |
| Technical Data and Dimensions | 10-11 |
| Electric Connections | 12 |
| Gas Connections | 13 |
| Gas Piping Installation | 14-15 |
| Gas service Installation Instructions | 16 |
| Gas Pipe Size Chart | 17 |
| Dryer Installation with Multiple Exhaust | 18-19 |
| Dryer Make-Up Air Requirements | 20 |
| Dryer Installation with Separate Exhaust | 21 |
| Exhaust and Venting | 22 |
| Rules for Safe Operation of Dryer | 23 |
| Direct-Spark Ignition Operation | 24-25 |
| General Maintenance | 26-27 |
| Operating Instruction for Double Timer | 28 |
| PARTS | 29-43 |

| | | | |
|--|----|---|----|
| Front View | 29 | Control Door Assembly | 30 |
| Front Panel Assembly | 31 | Thermostat Assembly | 32 |
| Wire Box Assembly | 33 | Door Assembly | 34 |
| Lint Door Assembly | 35 | Basket & Spider Assembly | 36 |
| Rear View | 37 | Air Switch Assembly | 38 |
| Basket Bearings/Sheave Assy | 39 | Motor & Fan Assembly | 40 |
| Idler Assembly | 41 | Rear Control Panel Assembly | 42 |
| Gas Heating Unit Assembly | 43 | | |

SYMBOLS

The following symbols are used in this manual and/or on the machine. The numbers between () refer to the numbers on the machine surveys.

| Symbol | Description | Symbol |
|---|--|---|
|  | NOTE! | |
|  | Hot! Do Not Touch Heiß! Nicht Berühren Haute temperature! Ne pas toucher Caliente! no tocar | |
|  | dangerous voltage tension dangereuse Gefährliche elektrische Spannung tension peligrosa | |
|  | On Marche Ein Conectado | |
|  | Off Arrêt Aus Desconectado | |
|  | Start Demarrage Start Arranque de un movimiento | |
|  | Emission of heat in general Emission de chaleur en general Warmeabgabe allgemein Emisión de calor | |
|  | Cooling Refroidissement Kühlen Enfriamiento | |
| | |  |
| | |  |
| | End of Cycle |  |
| | Caution Attention Achtung Atencion; precaucion |  |

Unpacking/General Installation (All Dryers)

UNPACKING

Upon arrival of the equipment, any damage in shipment should be reported to the carrier immediately.

Upon locating permanent location of a unit, care should be taken in movement and placement of equipment.

See outline clearance diagrams for correct dimensions.

Remove all packing material such as: tape, manuals, skid, etc

Leveling: Use spirit level on top of dryer. Adjust leveling bolts on dryer (see adjustable leveling bolts in maintenance section).

Check voltage and amperes on rating plate before installing the dryer.

**GENERAL
INSTALLATION
(ALL DRYERS)**

The construction of the dryers permits installation side-by-side to save space or to provide a wall arrangement. Position dryer for the least amount of exhaust piping and elbows, and allow free access to the rear of dryer for future servicing of belts, pulleys and motors. Installation clearance from all combustable material is 0" ceiling clearance, 0" rear clearance, and 0" side clearance.

Before operating dryer, open basket door and remove blocking between front panel and basket. Read the instruction tags, owner's manual, warnings, etc.

IMPORTANT

Opening the clothes loading door deactivates the door switch to shut off the motors, fan, gas, steam, or electric element. To restart the dryer, close the door and press in the push to start button.

IMPORTANT

This dryer is designed for a capacity maximum load. Overloading it will result in long drying times and damp spots on some clothes.

IMPORTANT

Maximum operating efficiency is dependent upon proper air circulation. The lint screen must be kept cleaned daily to insure proper air circulation throughout the dryer.

IMPORTANT

Provide adequate clearance for air opening into the combustion chamber.

**GENERAL
INFORMATION**

The dryer is so designed that when an operator opens the dryer door, the basket and exhaust fan stop. You can expect fast drying from a laundry dryer. Hot, dry air is properly and effectively moved through the basket and exhausted through a lint trap to the atmosphere. The dryer comes equipped with an inclined self-cleaning lint screen. In this system, lint accumulates on the underside of the screen until a blanket of lint will fall from the screen to the bottom of the dryer cabinet, and should be removed daily or as required, to prevent an over-accumulation.



IMPORTANT

Provide adequate clearance for air openings into the combustion chamber.

**DRYER
“COOL-DOWN”
CYCLE**

Permanent press, durable press and other modern day fabrics require the care that your laundry dryers now provide. At the end of the drying cycle, a timed “Cool-Down” control automatically takes over and continues the rotation of the fan and basket without heat until the garment load reaches a safe cool temperature. This function is performed at the end of each drying cycle and continues for two minutes.

**REPLACEMENT
PARTS**

Replacement parts for this dryer are available from your distributor or by contracting the factory at the address or phone number printed on the cover page of this manual.

75 lb. Dryer Dimensions - Standard Gas

| Specifications | U.S. Measure | Metric Measure | |
|---|----------------------|------------------------|-----------|
| Capacity (Dry Linen) | 75 lbs. | 34 kg | |
| Basket | | | |
| Diameter | 37 inches | 940 mm | |
| Depth | 36 inches | 914 mm | |
| Volume | 22.4 ft ³ | 634 liters | |
| Cabinet | | | |
| Height | 78-1/4 inches | 1988 mm | |
| Width | 39-1/4 inches | 997 mm | |
| Depth | 52 inches | 1321 mm | |
| Door Opening | | | |
| Diameter | 22-5/8 inches | 575 mm | |
| Loading height | 35-1/2 inches | 902 mm | |
| Temperature | | | |
| Minimum | 100° F | 38° C | |
| Maximum | 185° F | 85° C | |
| Motor | | | |
| Non-reversing | 3/4 HP | 0.56 kW | |
| Reversing - Drum | 1/2 HP | 0.37 kW | |
| Fan | 1/3 HP | 0.25 kW | |
| Exhaust | | | |
| Flow Rate | 1000 cfm | 1700 m ³ /h | |
| Diameter | 8 inches | 195-203 mm | |
| Electric Conn. - Electric Dryers | | Non-Reversing | Reversing |
| 208 V | 60 - 3 PH | 89 A | 88 A |
| 220/240 V | 50/60 - 3 PH | 72/78 A | 72/78 A |
| 380/415 V | 50 - 3 PH | 44/48 A | 43/46 A |
| 480 V | 60 - 3 PH | 38 A | 39 A |
| Electric Conn. - Steam, Gas Dryers | | Non-Reversing | Reversing |
| 120/208-240 V | 50/60 - 1 PH | 10.06/5.4 A | |
| 208/240 V | 50/60 - 3 PH | 4.2/4.1 A | 5.5/5.4 A |
| 480 V | 60 - 3 PH | 1.6 A | 2.5 A |
| 380/415 V | 50 - 3 PH | 1.7/1.8 A | 4.3/4.4 A |
| Power | | | |
| Electric | 30 kW | 30kW | |
| Gas | 185,000 Btu/h | 46,600 kcal/h | |
| Steam | 5.9 BHP | 49,842 kcal/h | |
| Steam connection | | | |
| Inlet | 3/4" | DN20 | |
| Outlet | 1/2" | DN15 | |
| Gas Connection | | | |
| Gas Connection | 3/4" | DN20 | |
| Gas Pressure | 6" - 12" | 15-30 mb | |
| Shipping Dimensions | | | |
| (H xW x D) | 87 X 42 X 57 inches | 2210 X 1067 X 1448 mm | |
| Weight | | | |
| Net | 798 lbs. | 362 kg | |
| Gross | 828 lbs. | 376 kg | |

DR75 Dryer Dimensions - Gas
(Illustration)

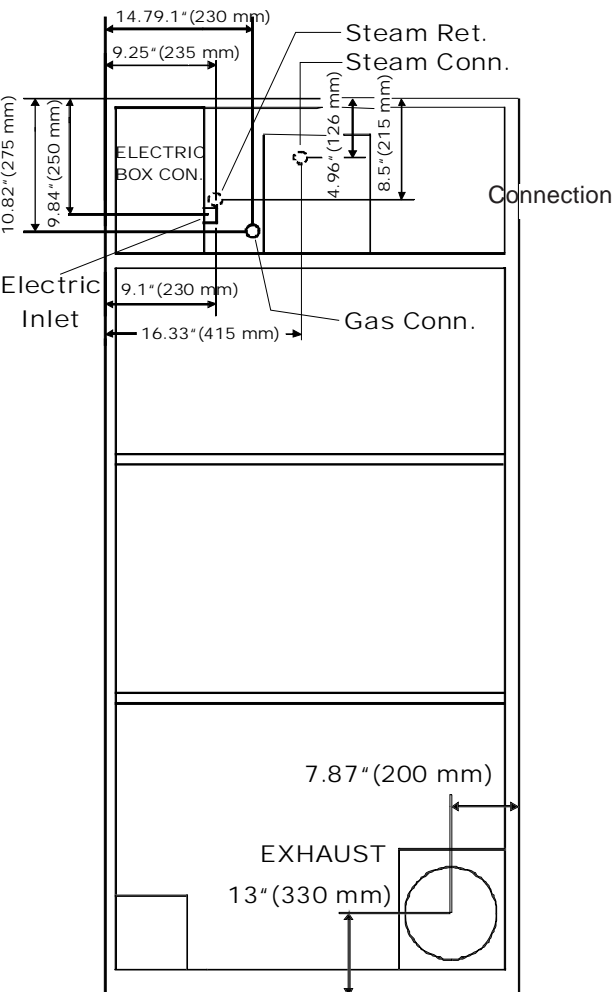
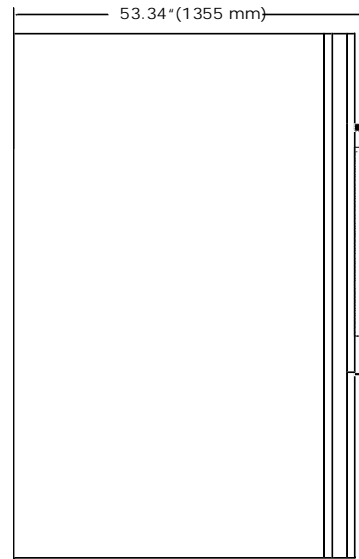
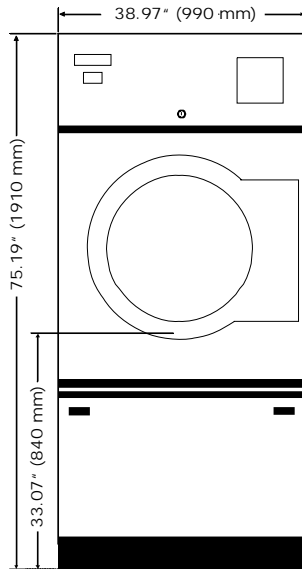

Electric connection

Dryers must be electrically grounded by a separate #14 or larger green wire from the **grounding terminal** within the Service Connection Box, to a cold water pipe. In all cases, the grounding method must comply with **local electrical code requirements**; or in the absence of local codes, with the *National Electrical Code, ANSI/NFPA No. 70 or the Canadian Electrical Code, CA C22.1.*

See wiring diagram furnished with dryer. **Do not change wiring without consulting the factory, as you may void the factory warranty. DO NOT CONNECT THE DRYER TO ANY VOLTAGE OR CURRENT OTHER THAN THAT SPECIFIED ON THE DRYER RATING PLATE.** (Wiring diagram is located on rear wall of dryer.)

All panels must be in position before operation of dryer.

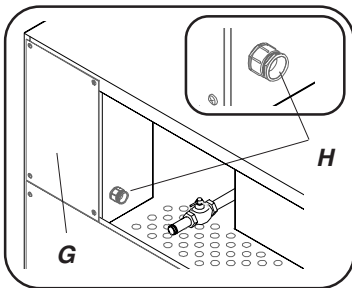

The connection needs to be made in the wiring box at the back. Remove the coverplate (G) in order to reach the connection clamps.

The connection cable needs to be brought in through the swivel (H) on the *side of the wiring box.*



It is necessary to **ground** the dryer for your personal safety and to ensure a good operation.

115 and 208-240 V - 1 ph

The mains wires (L1) and (L2) should be connected to the 2 left clamps and the **yellow/green grounding wire (PE)** should be connected to the grounding clamp.

208-240 and 480 V - 3 ph

The **3 mains wires (L1), (L2) and (L3)** should be connected to the 3 left clamps and the **yellow/green grounding wire (PE)** should be connected to the grounding clamp.

380-415V - 3 ph

The **3 mains wires (L1), (L2) and (L3)** should be connected to the 3 left clamps, the **blue neutral (N)** should be connected to the right clamp and the **yellow/green grounding wire (PE)** should be connected to the grounding clamp.

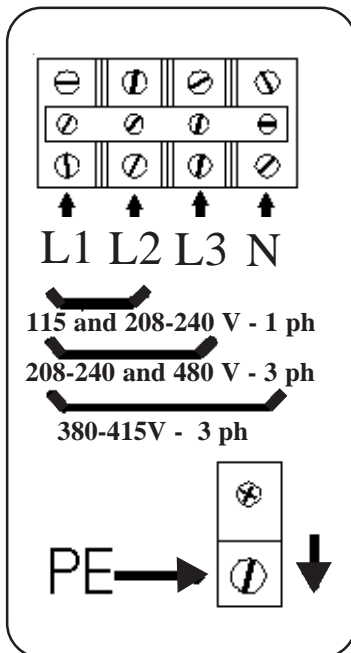

«Attention. Lors des opérations d'entretien des commandes, étiqueter tous les fils avant de les déconnecter. Toute erreur de câblage peut être une source de danger et de panne»

Gas connection

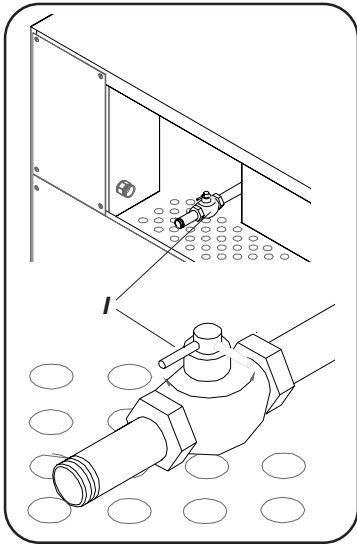

The gas supply pipe should be connected *to the gas tap (I), which is on the right next to the wiring box on the back.*

It is very important to have the connections done by a qualified technician, in order to make sure that the installation is effected in accordance with the prevailing standards and instructions.

The dryer should be connected to the type of gas, which is indicated on the serial plate.

The use *of too small gas pipes* can result in insufficient gas supply, which can lead to a bad heating-up and a poor drying quality.

When the dryer is used in combination with a weighing platform, the gas supply pipe has to be made of flexible material to allow the weighing system to keep moving freely.



Test all clutches and connections for possible leaks by means of a soap solution, but *never with a flame.*

It is important to work with the right gas pressure (see technical remarks) in order to obtain a good ignition, heating and consequently a good operation in general.

After the gas supply has been connected, the gas tap in the dryer should be turned on (clockwise).

**GAS PIPING
INSTALLATION**

1. The installation must conform with local codes, or in the absence of local codes with the *National Fuel Gas Code, ANSI Z223.1 or the CAN/CGA-B149, Installation Codes.*
2. Check Identification Nameplate for type of gas for dryer.
3. Check for altitude elevation of dryer.
4. Check with utilities company for proper gas pressure and gas supply line.
5. Natural Gas Only—Check the gas pressure inlet supply to dryer, 11 inches water column (27.4 mbar) maximum. Manifold Pressure—3.5 inches water column (8.8 mbar) pressure.
6. L.P. Gas Only—Manifold pressure—13 inches water column (32.4 mbar) maximum.

CAUTION: Low gas pressure and intermittent gas will cause gas ignition problems and inadequate drying of laundry.

Gas Piping Installation (Illustrations)

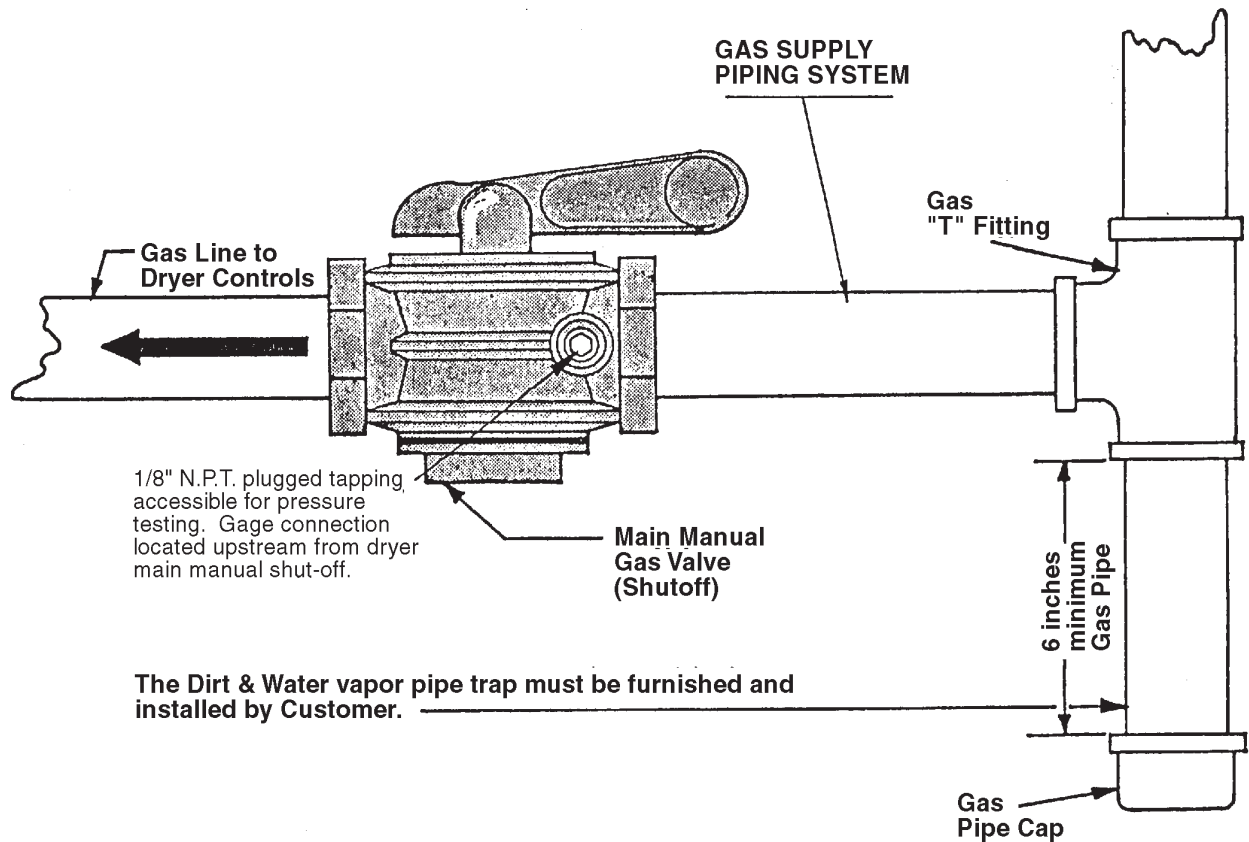

The dryer and its individual shutoff valve must be disconnected from the gas supply piping system during any pressure testing of that system at test pressures in excess of 1/2 psig (.04 bar).

The dryer must be isolated from the gas supply piping system by closing its individual manual shutoff valve during any pressure testing of the gas supply piping system at test pressures equal to or less than 1/2 psig (.04 bar).

Gas Service Installation Instructions

GAS SERVICE INSTALLATION INSTRUCTIONS

The size of the gas service pipe is dependant upon many variables, such as tees, lengths, etc. Specific pipe size should be obtained from the gas supplier. Refer to the "Gas Pipe Size" chart in this manual for general gas pipe size information.

CAUTION: Gas loop piping must be installed as illustrated to maintain equal gas pressure for all dryers connected to a single gas service

Other gas-using appliances should be connected upstream from the loop.

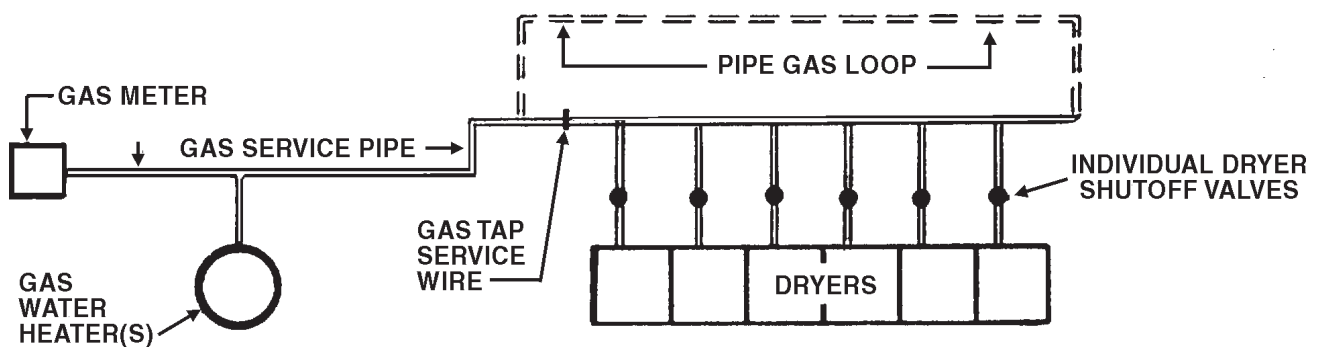

WARNING:
LIQUIFIED PETROLEUM GASES ONLY !

GAS PRESSURE REGULATOR FOR LIQUIFIED PETROLEUM GASES

A Gas Pressure Regulator for Liquified Petroleum Gases is not furnished on Gas Heated Clothes Dryers. This regulator is normally furnished by the installer. In accordance with American Gas Association (AGA) standards, a gas pressure regulator, when installed indoors, must be equipped with a vent limiter or a vent line must be installed from the gas pressure regulator vent to the outdoors.

Gas Pipe Size Chart

| TOTAL BTU/HR (for LP Gas correct total BTU/HR below by multiplying by .6) | TOTAL KCAL | GAS PIPE SIZE FOR 1000 BTU (250 KCAL) NATURAL GAS AT 7" (17.5 MBAR) W.C. PRESSURE | | | | | |
|--|---------------|--|---------------------|---------------------|----------------------|---------------------|----------------------|
| | | In figuring total length of pipe, make allowance for tees and elbows. | | | | | |
| | | (25 ft.) 7,62 m | (50 ft.) 15,24 m | (75 ft.) 22,86 m | (100 ft.) 30,48 m | (125 ft.) 38,1 m | (150 ft.) 45,72 m |
| 60,000 | 15000 | 3/4 | 3/4 | 3/4 | 3/4 | 3/4 | 3/4 |
| 80,000 | 20000 | 3/4 | 3/4 | 3/4 | 1 | 1 | 1 |
| 100,000 | 25200 | 3/4 | 3/4 | 1 | 1 | 1 | 1 |
| 120,000 | 30200 | 3/4 | 1 | 1 | 1 | 1 | 1 |
| 140,000 | 35200 | 3/4 | 1 | 1 | 1 | 1 | 1 1/4 |
| 160,000 | 40300 | 3/4 | 1 | 1 | 1 1/4 | 1 1/4 | 1 1/4 |
| 180,000 | 45300 | 1 | 1 | 1 | 1 1/4 | 1 1/4 | 1 1/4 |
| 200,000 | 50400 | 1 | 1 | 1 1/4 | 1 1/4 | 1 1/4 | 1 1/2 |
| 300,000 | 75600 | 1 | 1 1/4 | 1 1/4 | 1 1/2 | 1 1/2 | 1 1/2 |
| 400,000 | 100800 | 1 1/4 | 1 1/4 | 1 1/2 | 1 1/2 | 1 1/2 | 2 |
| 500,000 | 126000 | 1 1/4 | 1 1/2 | 1 1/2 | 2 | 2 | 2 |
| 600,000 | 151200 | 1 1/2 | 1 1/2 | 2 | 2 | 2 | 2 |
| 700,000 | 176400 | 1 1/2 | 2 | 2 | 2 | 2 | 2 1/2 |
| 800,000 | 202000 | 1 1/2 | 2 | 2 | 2 | 2 1/2 | 2 1/2 |
| 900,000 | 230000 | 2 | 2 | 2 | 2 1/2 | 2 1/2 | 2 1/2 |
| 1,000,000 | 250000 | 2 | 2 | 2 | 2 1/2 | 2 1/2 | 2 1/2 |
| 1,100,000 | 270000 | 2 | 2 | 2 1/2 | 2 1/2 | 2 1/2 | 2 1/2 |
| 1,200,000 | 300000 | 2 | 2 | 2 1/2 | 2 1/2 | 2 1/2 | 2 1/2 |
| 1,300,000 | 330000 | 2 | 2 1/2 | 2 1/2 | 2 1/2 | 2 1/2 | 3 |
| 1,400,000 | 350000 | 2 | 2 1/2 | 2 1/2 | 2 1/2 | 3 | 3 |
| 1,500,000 | 380000 | 2 | 2 1/2 | 2 1/2 | 2 1/2 | 3 | 3 |
| 1,600,000 | 400000 | 2 | 2 1/2 | 2 1/2 | 3 | 3 | 3 |
| 1,700,000 | 430000 | 2 | 2 1/2 | 2 1/2 | 3 | 3 | 3 |
| 1,800,000 | 450000 | 2 1/2 | 2 1/2 | 3 | 3 | 3 | 3 |
| 1,900,000 | 480000 | 2 1/2 | 2 1/2 | 3 | 3 | 3 | 3 |
| 2,000,000 | 504000 | 2 1/2 | 2 1/2 | 3 | 3 | 3 | 3 1/2 |
| 2,200,000 | 550000 | 2 1/2 | 3 | 3 | 3 | 3 1/2 | 3 1/2 |
| 2,400,000 | 605000 | 2 1/2 | 3 | 3 | 3 | 3 1/2 | 3 1/2 |
| 2,600,000 | 650000 | 2 1/2 | 3 | 3 | 3 1/2 | 3 1/2 | 3 1/2 |
| 2,800,000 | 705000 | 2 1/2 | 3 | 3 | 3 1/2 | 3 1/2 | 3 1/2 |
| 3,000,000 | 750000 | 2 1/2 | 3 | 3 1/2 | 3 1/2 | 3 1/2 | 4 |
| 3,200,000 | 806000 | 3 | 3 | 3 1/2 | 3 1/2 | 3 1/2 | 4 |
| 3,400,000 | 850000 | 3 | 3 1/2 | 3 1/2 | 3 1/2 | 4 | 4 |
| 3,600,000 | 907000 | 3 | 3 1/2 | 3 1/2 | 3 1/2 | 4 | 4 |
| 3,800,000 | 960000 | 3 | 3 1/2 | 3 1/2 | 4 | 4 | 4 |
| 4,000,000 | 1000000 | 3 | 3 1/2 | 3 1/2 | 4 | 4 | 4 |

Dryer Installation With Multiple Exhaust

For Exhaust Duct less than 14 feet (5 m) and 2 elbows equivalent and less than 0.3 inches (8 mm) static pressure.

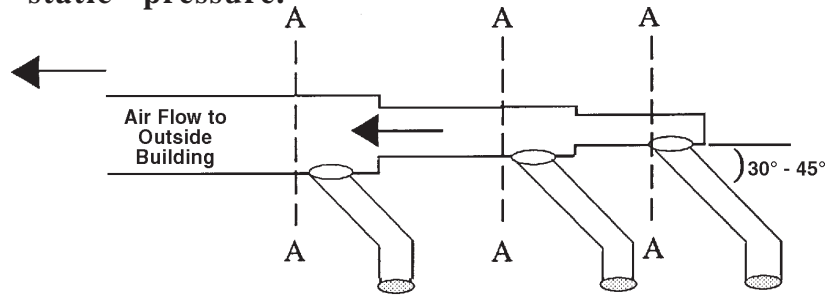

DRYER EXHAUSTS

Area of section "A-A" must be equal to the sum of dryer exhaust pipes entering multiple exhaust pipe. (See chart below.)

| DR75 | |
|------------------------------|--|
| No. of Dryers | 1 2 3 4 5 6 7 8 9 10 11 12 13 14 15 16 17 18 19 20 21 22 23 24 |
| Duct Diameter (in inches) | 8 12 14 16 18 20 22 23 24 26 27 28 29 30 31 32 33 34 35 36 37 38 39 40 |
| (in CM) | 20 30 25 41 46 51 56 58 61 66 68 71 73 76 78 81 84 86 89 91 94 97 99 100 |

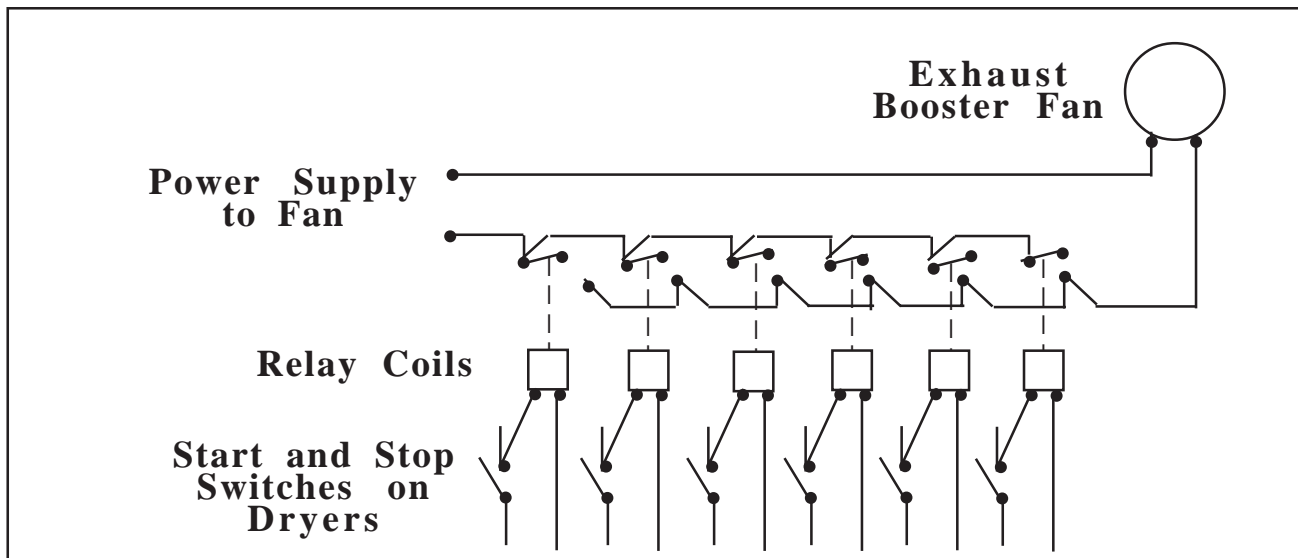

Dryer Installation with Multiple Exhaust

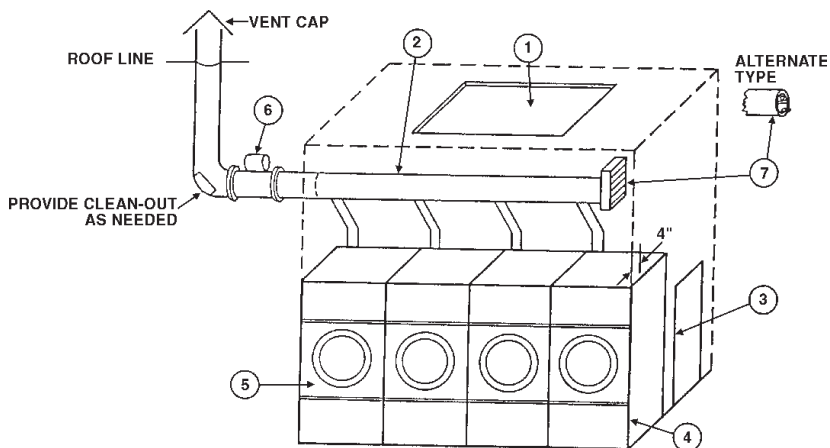

DRYER INSTALLATION WITH MULTIPLE EXHAUST

For Exhaust Duct more than 14 feet (5 m) and 2 elbows equivalent and more than 0.3 inches (8 mm) static pressure. (See illustration on page 21.)

1. Make-up air from outside building may enter enclosure from top or side walls. (See *Dryer Make-Up Air Requirements Chart*)
2. Use constant diameter duct with area equal to the sum of dryer duct areas.
EXAMPLE: Six 8 inch (204 mm) diameter duct = one 19.6 inch (498 mm) diameter duct in area. Use 20 inch (508 mm) diameter duct or diameter to match tube-axial fan.
3. Enclosure (plenum) with service door. This separates the dryer air from room comfort air. If dryers use room air instead of outside air, the heat loss can be another 25 Btu/hr (6.3 kcal/hr) for each cubic foot per minute (cfm) used.
4. Zero inches clearance to combustible material allowed on sides and at points within 4 inches (102 mm) of front on top.
5. Heat loss into laundry room from dryer fronts *only* is about 60 Btu/hr per square foot (15 kcal/hr per 0.1m²).
6. Flange mounted, belt driven tube-axial fan. **Fan must run when one or more dryers are running.** See suggested *Automatic Electrical Control Wiring Diagram* on previous page. Must meet local electrical codes. Fan air flow (cfm) (m³/min.) is equal to sum of dryer air flows, but static pressure (SP) is dependent on length of pipe and number of elbows.
7. **Barometric Bypass Damper**—Adjust to *closed flutter position* with all dryers and exhaust fan running. **Must be located within enclosure.**



CAUTION: *Never install hot water heaters or other gas appliances in the same room as dryers. Never install cooling exhaust fans in the same room as dryers.*

CAUTION: *Never exhaust dryers with other types of equipment.*

Suggested Minimum Dryer Make-up Air Requirements

| Dryer Model | Dryer Pocket Capacity | | Maximum Air Flow Rate per Pocket | | Duct Size For Service Connection | | Required Make-up Air Area per Pocket | |
|-------------|-----------------------|------|----------------------------------|------|----------------------------------|-----|--------------------------------------|------|
| | lb | kg | cfm | m3/h | inch | mm | sq. inch | cm2 |
| C 30 | 30 | 13.6 | 700 | 1190 | 8 | 203 | 135 | 871 |
| C 30 E/S | 30 | 13.6 | 400 | 680 | 6 | 153 | 77 | 497 |
| C 30 ST | 30 | 13.6 | 450 | 765 | 6 | 153 | 87 | 561 |
| C 50 | 50 | 22.7 | 800 | 1360 | 8 | 203 | 154 | 994 |
| C 50 E/S | 50 | 22.7 | 450 | 765 | 6 | 153 | 87 | 561 |
| C 75 | 75 | 34 | 1000 | 1700 | 8 | 203 | 192 | 1239 |
| C 75 E/S | 75 | 34 | 536 | 911 | 6 | 153 | 103 | 665 |
| C 75 ST | 75 | 34 | 1000 | 1700 | 12 | 305 | 192 | 1239 |
| HD80 | 80 | 36.3 | 1465 | 2490 | 10 | 254 | 282 | 1819 |
| C 110 | 110 | 50 | 2200 | 3740 | 12 | 305 | 422 | 2723 |
| C 110 E/S | 110 | 50 | 850 | 1445 | 8 | 203 | 163 | 1052 |
| C 125 | 125 | 56.7 | 2000 | 3400 | 12 | 305 | 384 | 2477 |
| C 150 | 150 | 68 | 2250 | 3825 | 12 | 305 | 432 | 2787 |
| HD175 | 175 | 79.4 | 2780 | 4726 | 12 | 305 | 534 | 3445 |
| HD190 | 190 | 86.2 | 3000 | 5100 | 12 | 305 | 576 | 3716 |
| WMC/HD20 | 20 | 9.1 | 450 | 765 | 6 | 153 | 87 | 561 |
| WMC/HD30 | 30 | 13.6 | 625 | 1063 | 8 | 203 | 120 | 774 |
| WMC/HD50 | 50 | 22.7 | 700 | 1190 | 8 | 203 | 135 | 871 |
| WMC/HD75 | 75 | 34 | 750 | 1275 | 8 | 203 | 144 | 929 |

Notes:

- 1) The Model C 30 ST has 2 pockets per dryer, each pocket has the above listed characteristics; each pocket is exhausted separately with a 6" (153mm) duct.
- 2) The Model C 75 ST has 2 pockets per dryer, each pocket has the above listed characteristics; both pockets have one 8" (203mm) exhaust manifolded into one 12" (305mm) exhaust duct for exhaust connection.
- 3) For the C 30 ST and the C 75 ST Models, the Required Make-up Air Area shown in the table should be doubled since it is shown per pocket, only.
- 4) E/S indicates an Energy Saving Model.

Dryer Installation With Separate Exhaust (Preferred)

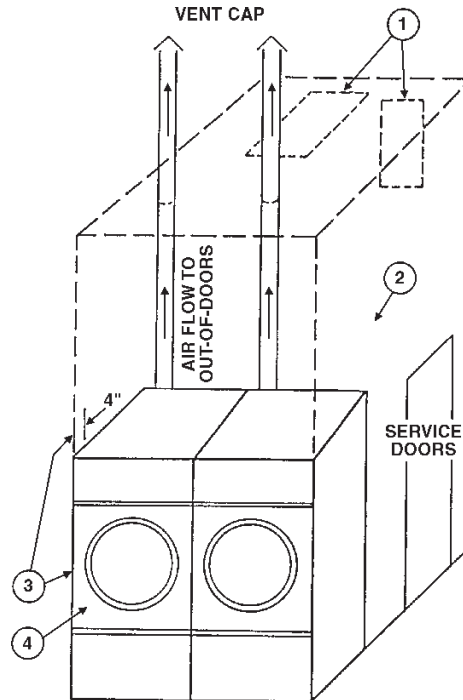

DRYER INSTALLATION WITH SEPARATE EXHAUST (PREFERRED)



For ductwork less than 14 feet (5 m) and 2 elbows equivalent and less than 0.3 inches (8 mm) static pressure:

NEVER exhaust the dryer into a chimney.

NEVER install wire mesh screen over the exhaust or make-up air area.

NEVER exhaust into a wall, ceiling, or concealed space.

1. Make-Up Air opening from outside the building may enter the enclosure from the top or side walls. (*See Dryer Make-Up Air Chart*)
2. Enclosure (plenum) with service door. This separates the dryer air from the room comfort air. If dryers use room air instead of outside air, additional heat loss can be another 25 Btu/hr (6.3 kcal/hr) for each cubic foot per minute (cfm) (.03m³/min.) used.
3. Zero inches (mm) clearance to combustibile material allowed on sides and at points within 4 inches (102 mm) of front on top.
4. Heat loss into laundry room from dryer front panels is about 60 btu/hr per square foot (15 kcal/hr per 0.1m²).

Exhaust and Venting

DRYER AIR FLOW INSTALLATION

Nothing is more important than air flow for the proper operation of a clothes dryer. A dryer is a pump which draws make-up air from the out-of-doors, through the heater, through the clothes and then forces the air through the exhaust duct back to the out-of-doors. Just as in a fluid water pump, there must be a fluid air flow to the inlet of the dryer, if there is to be the proper fluid air flow out of the exhaust duct.

In summary, there must be the proper size out-of-doors inlet air opening (4-6 times the combined areas of the air outlet) and an exhaust duct, size and length of which allows flow through the dryer with no more than 0.3 inches water column (.8 mbar) static pressure in the exhaust duct.

In some instances, special fans are required to supply make-up air, and/or boost exhaust fans are required for both regular and energy saving models.

EXHAUSTING DUCT

FOR BEST DRYING:

1. Exhaust duct maximum length 14 feet (5 m) of straight duct and maximum of two 90° bends.
2. Use 45° and 30° elbows wherever possible.
3. **Exhaust each dryer separately.**
4. Use 2 feet (0.6 m) of straight duct on dryer before installing an elbow on Energy-Saver models only.
5. **Do not** install wire mesh or other restrictions in the exhaust duct.
6. Use clean-outs in the exhaust duct and clean periodically when needed.
7. **Never** exceed 0.3 inches water column (.8 mbar) static pressure in the exhaust duct.
8. Inside surface of the duct **must be smooth.**
9. Recommend pop rivets for duct assembly.

MAKE-UP AIR

FOR BEST DRYING:

1. Provide opening to the out-of-doors in accordance with the following:
For each dryer—
6 inches (2 m) diameter exhaust requires a 1 square feet (0.1 m²) opening for make-up air.
8 inches (3 m) diameter exhaust requires a 2 square feet (0.2 m²) opening for make-up air.
12 inches (4 m) diameter exhaust requires a 4 square feet (0.4 m²) opening for make-up air.
2. Use barometric shutters in the inlet air opening to control air when dryers are not running.

OTHER RECOMMENDATIONS

Other Recommendations

To assure compliance, consult local building code requirements.

TROUBLESHOOTING

Troubleshooting

Hot dryer surfaces, scorched clothes, slow drying, lint accumulations, or air switch malfunction are indicators of exhaust duct and/or make-up air problems.

Rules for Safe Operation of Dryer

1. **Be sure** your dryer is installed properly in accordance with the recommended instructions.
 2. **CAUTION**
Be safe—**shut main electrical power supply and gas supply off externally before attempting service.**
 3. **CAUTION**
Never use drycleaning solvents: gasoline, kerosene, or other flammable liquids **in the dryer.** ***Fire and explosion will occur.***
Never put fabrics treated with these liquids into the dryer.
Never use these liquids near the dryer.
Always keep the lint screen clean.
Never use heat to dry items that contain plastic, foam or sponge rubber, or rags coated with oils, waxes or paints. **The heat may damage the material or create a fire hazard.**
Rubber easily oxidizes, causing excessive heat and possible fire.
Never dry the above items in the dryer.
 4. **Never let children play near or operate the dryer.**
Serious injury will occur if a child should crawl inside and the dryer is turned on.
 5. **Never** use dryer door opening and top as a step stool.
 6. **Read** and follow manufacturer's instructions on packages of laundry and cleaning aids. Heed any **warnings** or **precautions.**
 7. **Never** tumble fiberglass materials in the dryer unless the labels say they are machine dryable. Glass fibers break and can remain in the dryer and could cause skin irritation if they become mixed into other fabrics.
 8. **Reference**
Lighting and shut-down instructions and wiring diagrams are located on the rear wall of the dryer cabinet.
 9. **The dryer must not be installed or stored in an area where it will be exposed to water and/or weather.**
-
1. Install dryer so that you can use short, straight venting. Turned elbows and long vent tubing tend to increase drying time. Longer drying time means the use of more energy and higher operating costs.
 2. Operate dryer using full-size loads. Very large loads use extra energy. Very small loads waste energy.
 3. Dry light-weight fabrics separately from heavy fabrics. You will use less energy and get more even drying results by drying fabrics of similar weight together.
 4. Clean the lint screen area daily. A clean lint screen helps give faster, more economical drying.
 5. **Do not** open the dryer door while drying. You let warm air escape from the dryer into the room.
 6. Unload the dryer as soon as it stops. This saves having to re-start your dryer to remove wrinkles.

Direct-Spark Ignition Operation

DIRECT SPARK IGNITION OPERATION

NOTE: All HD dryers manufactured by are equipped with the DSI (Direct Spark Ignition) modules. These are designed to increase dryer efficiency and to reduce dryer operating costs. The main burner is directly ignited from a spark electrode. A burning flame provides an electrical path for a small amount of sensing current to allow gas valve operation. If the main burner flame extinguishes for any reason (aside from the thermostatic control) sensing current will shut down the gas valve and the spark ignition circuit.

1. Once flame is established, the spark shuts off, and the main burner flame is then electronically monitored by means of a sensing spark probe which is located over the burner. The gas valve remains energized (open).
2. If no flame is detected within the first 11 seconds the DSI will go into a safety "lock-out". The gas valve is energized.
3. If recovery from a safety lockout requires one of the following:
 - A. Opening the main door thus interrupting power to the DSI module and allowing dryer diagnostic trouble shooting.
 - B. Disconnecting the entire dryer from a power source using a circuit breaker or a switch.
4. By closing the main door the ignition circuit will be restored for another trial of the ignition circuit.
5. Once the thermostatic control has been satisfied by reaching a pre-set temperature or the drying timer has been timed out, the ignition circuit will be de-energized thus extinguishing the flames.
6. The dryer will continue to run in a cool-down mode without heat. This process will cool the load to the touch and help to eliminate wrinkling.
7. The cool - down time is pre-set on some models and manually set on other dryer models. The cool-down cycle prevents fabric wrinkles by allowing clothes to reach room ambient temperature while still in a continuous levitation state until clothes are ready to be folded or pressed.

***DIRECT SPARK
IGNITION OPERATION
FLOW CHART***

The DSI module is powered by a 24 volt AC supplied by a step-down transformer in series with eight safety interlocks:

- A. Timer Switching Device (1)
- B. Main Door and Lint Door Switches (2)
- C. Sail Switch (1)
- D. Under Basket and Burner Housing Thermal Safety Switches (2)
- E. Variable Thermostat (1)
- F. Push to Start Switch (1)

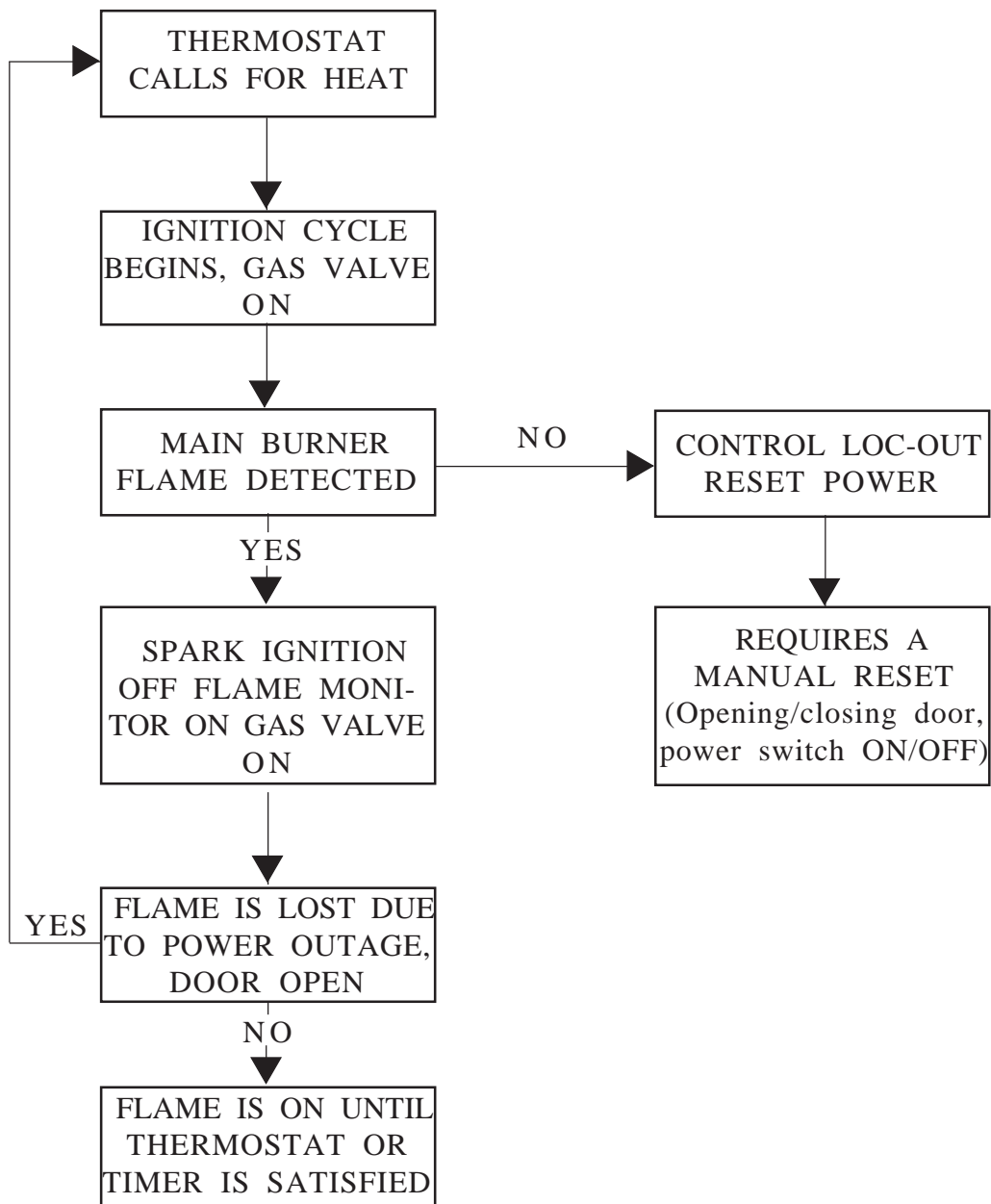

**GENERAL
MAINTENANCE**

1. **Clean lint trap daily.** Remove lint before or after each day of operation. A clean lint trap will increase the efficiency of the dryer and the moisture-laden air will be exhausted outside more quickly.
2. **Keep basket and sweep sheets clean.** Clean as often as needed. The basket and sweep sheets are accessible by removing the front panel of the dryer.
3. **Gas burners, steam coils, electric coils.** Check and clean often.
4. **Pulleys and belts.** Keep clean, as oil and dirt will shorten the life of a belt. Check periodically for alignment. Pulley shafts must be parallel and the grooves must be aligned. Check belt tension periodically. Adjust tension by movement of Idler Bracket. Lubricate Idler Pulley once every two months, using six grams of high temperature grease. **Do not over-grease.**
5. **Electric motor.** Keep motor clean and dry. Motors are packed with sufficient grease for 10 years normal service. After that, bearings and housing should be cleaned and repacked one-third full with Chevron Grease No. SR1-2. See label on motor for further information.

If motor overheats, check voltage and wiring. Low voltage, inadequate wiring and loose connections are the main cause of motor failures.

6. **Adjustable leveling bolts.** One at each corner permits accurate alignment of dryer.
To adjust: Block one corner of dryer up off the floor, loosen hex nut. With wrench, turn bolt clockwise to raise dryer, opposite to lower. Rear bolts are outside of dryer and front bolts are inside lint trap compartment.

General Maintenance

**GENERAL
MAINTENANCE
(continued)**

7. **Periodically clean** and examine exhaust system.

8. **Keep dryer area clean** and free of gasoline, combustible materials and other flammable liquids or vapors.

9. **Do not obstruct the flow** of combustion (make-up) air and ventilating air.

10. **Check gas pressure** periodically.

OPERATING INSTRUCTION - DOUBLE TIMER

OPERATING INSTRUCTIONS - DOUBLE TIMER MODELS

1. After loading the dryer with water washed clothes, close the loading door.
2. Turn the 60 minute drying (heat) timer to the desired time.
3. Turn the 60 minute cooling (air) to the desired time.
4. Select the temperature desired: Low, Medium, or High.
HIGH HEAT
175° F (80° C) exhaust temperature, heavy fabrics and hard to dry, such as cottons, towels, denim, etc..
PERMANENT PRESS (medium)
155° F (69° C) exhaust temperature, synthetic blends, including a mixed wash load.
LOW HEAT
135° F (58°) exhaust temperature, delicate, sheer fabrics.
5. Press the “push to start” button to start the drying cycle. The heat or drying light will stay on until the drying cycle is completed
6. At the end of the drying cycle, the cool down cycle will automatically count down until all time runs out. The cool down light will stay on until the end of the cycle.
7. Drying cycle will not start unless a few minutes of the cool-down cycle are set on the cool-down timer.
8. To shut the dryer off at any time during the cycles by opening the door.

FRONT VIEW

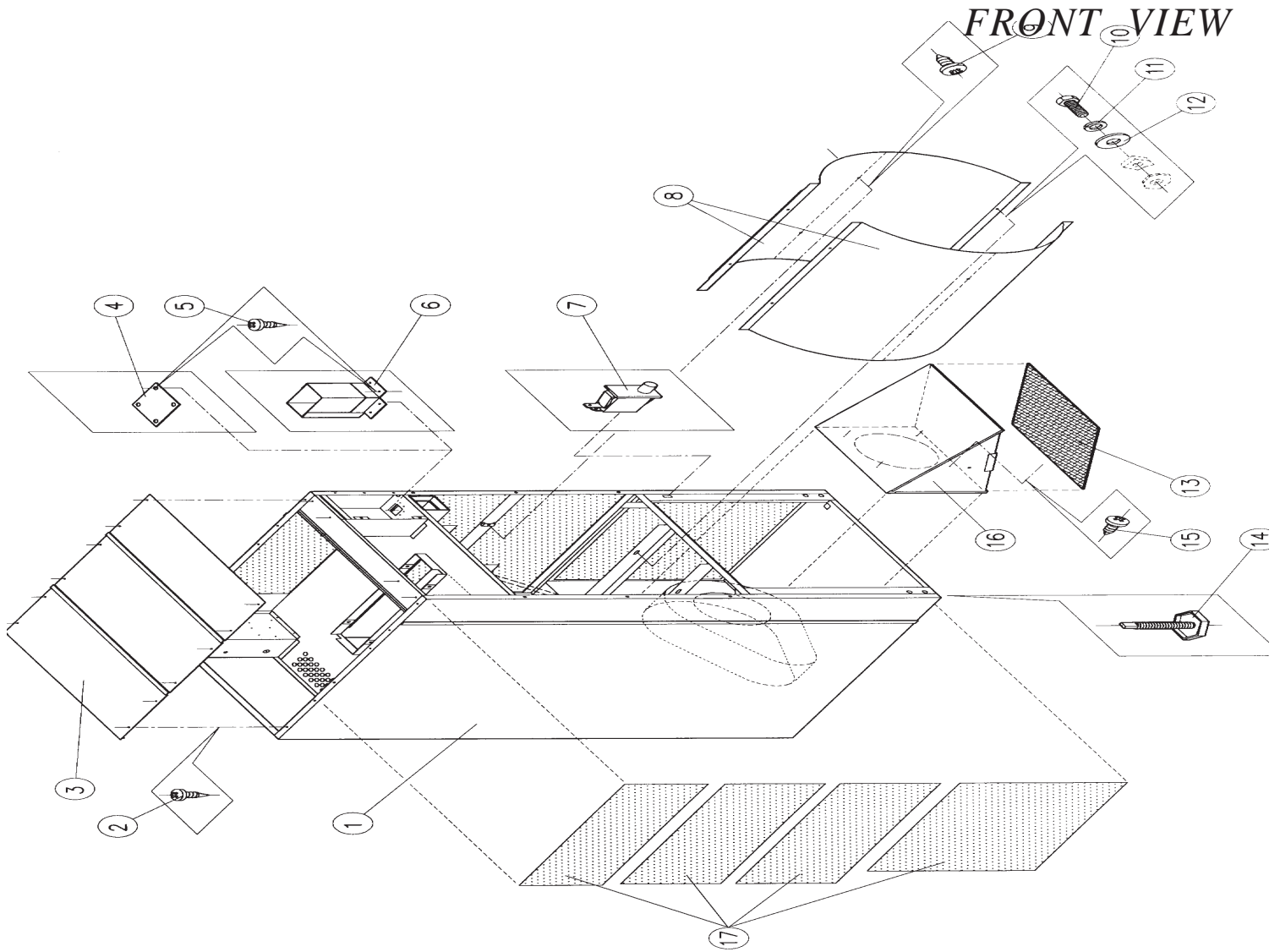

| Ref. No. | PartNo. | Description |
|----------|-------------|-------------------------------|
| 1 | CSA-50045WH | Jacket gas/electric (white) |
| 1 | CSA-50052WH | Jacket steam (white) |
| 2 | TU7733 | Screw selfdrilling 8-18X1/2" |
| 3 | CA-13027-0 | Top panel |
| 4 | CSA-11546-0 | Cover plate (non-coin models) |
| 5 | TU7733 | Screw selfdrilling 8-18X1/2" |
| 6 | CSA-01435-0 | Coin chute w/a |
| 7 | EA-00650-0 | Microswitch door |
| 8 | CA-13026-0 | Right sweep sheet |
| 9 | CA-13026-0 | Left sweep sheet (gas & elec) |
| 9 | CA-13095-0 | Right sweep sheet (steam) |

| Ref. No. | PartNo. | Description |
|----------|-------------|---|
| 10 | CB36 | Screw-hex 1/4-20X1/2" |
| 11 | TU2846 | Lockwasher 1/4" medium |
| 12 | TU2847 | Washer 1/4" |
| 13 | CA-13085-0 | Lint frame |
| 13 | CA-13035-0 | Lint Screen |
| 14 | TU3211 | Leveling bolt |
| 15 | TU7733 | Screw selfdrilling 8-18X1/2" |
| 16 | CSA-01545-0 | Support filter |
| 17 | CSA-01512-0 | Insulation inside WMC complete -used on gas models only- |

CONTROL DOOR ASSEMBLY

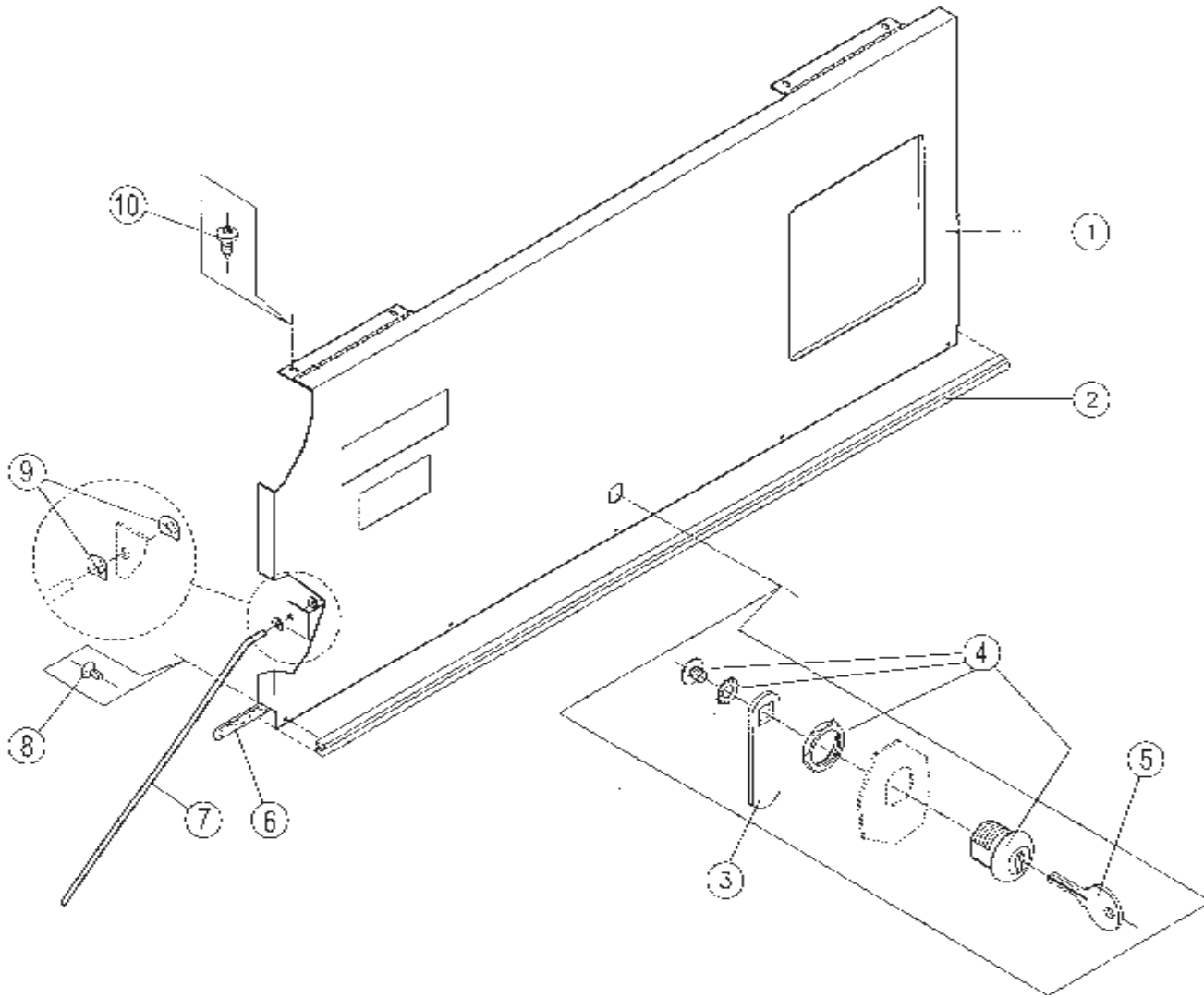

CSA-01510WH

Complete control doorassy.

Note: Door rodassy. is not part of above completeassy.

| Ref. No. | Part No. | Description |
|----------|-------------|--------------------------------|
| 1 | CSA-01511WH | Control doorassy. |
| 2 | CA-00858-0 | Trim-Control door |
| 3 | CA-11941-0 | Cam Lock-Control door |
| 4 | CA-00121-0 | Lock-Control door |
| 5 | CA-00119-0 | Key-Control door |
| 6 | CA-13098-0 | Gasket |
| 7 | CA-10085-0 | Support rod |
| 8 | SB-00951-0 | Screw-Phillips#8X7/16 flat hd. |
| 9 | SB-00971-0 | Tinnerman push-on fastener |
| 10 | TU7733 | Screw selfdrilling 8-18*1/2" |

FRONT PANEL ASSEMBLY

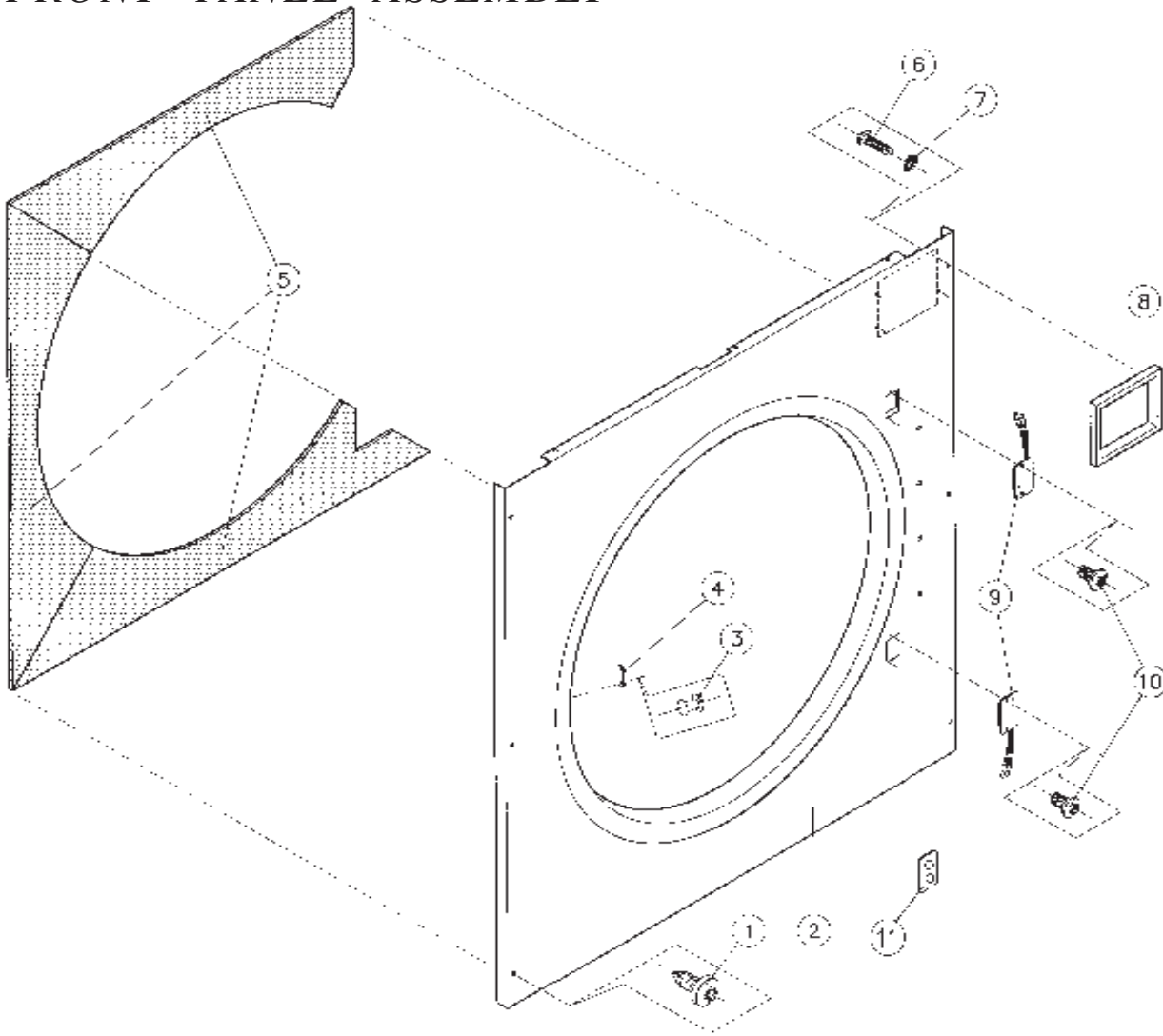

| Ref. No. | PartNo. | Description |
|----------|-------------|------------------------------|
| 1 | SB-00915-0 | Screwselfdrilling#10-16X5/8 |
| 2 | CSA-01523WH | Frontpanel, weldedassy.-Coin |
| 2 | CSA-01513WH | Frontpanel, weldedassy-OPL |
| 3 | TU3213 | PopRivet PVDdoor.locker |
| 4 | TU2876 | Latchstrap |
| 5 | CA-00676 | Insulation |
| 6 | SB-00924-0 | Screw4-40*3/8taptite |
| 7 | SB-00938-0 | Washer4external.tooth |
| 8 | CA-00699-0 | Bezel -Coinbox |
| 9 | ESA-00862-0 | Reedswitchassy. |
| 10 | SB-009775-0 | Screw6-32*1/4phillips |
| 11 | EA-00827-0 | Mountingplate-Reedswitch |

THERMOSTAT ASSEMBLY

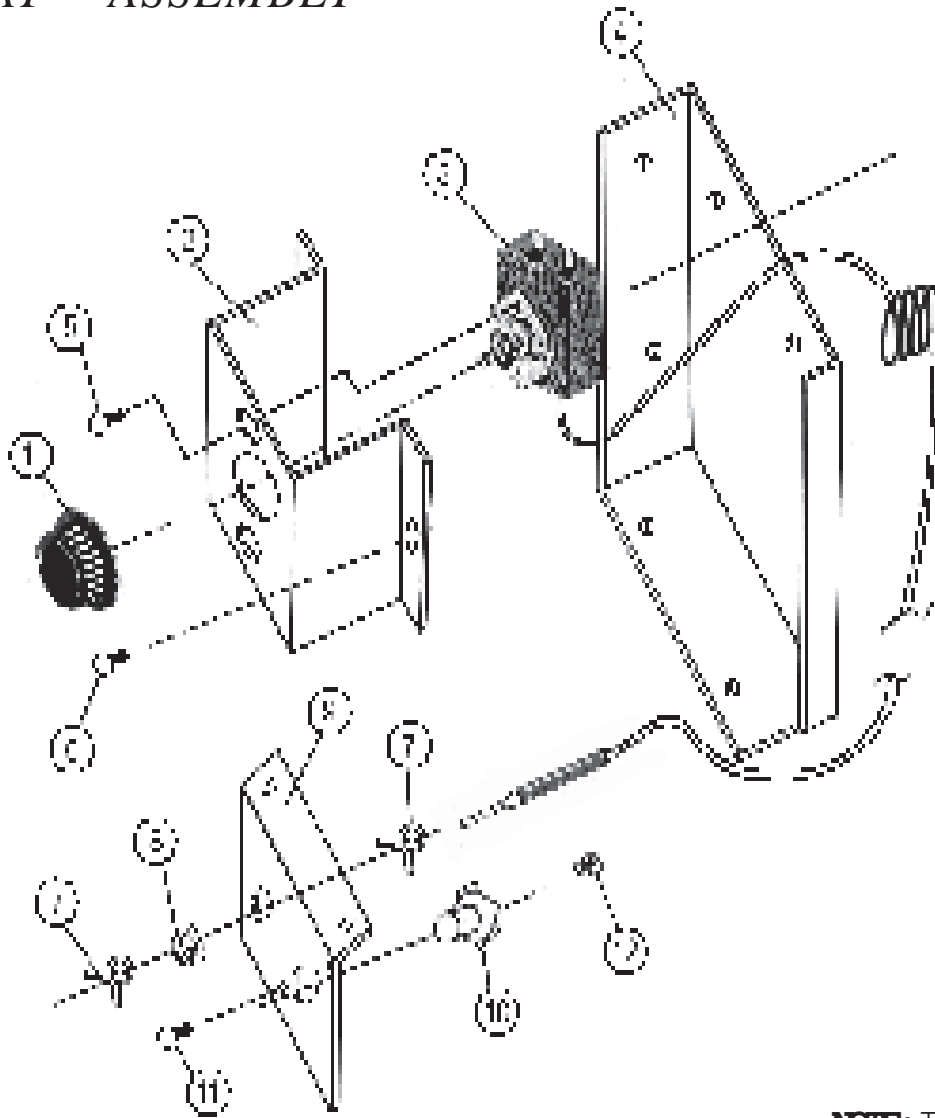

NOTE: Items 1 thru 6 mounted in front wire box. Items 7 thru 12 are mounted under the basket

| Ref. No. | Part No. | Description |
|----------|------------|------------------------------|
| 1 | EA-00607-0 | Thermostat knob |
| 2 | CA-13213-0 | Thermostat bracket |
| 3 | EA-00606-0 | Thermostat |
| 4 | CA-13215-0 | Thermostat bracket adapter |
| 5 | TU3624 | Screw 6 - 32X1/4" |
| 6 | TU7733 | Screw-selfdrilling 8-18X1/2" |
| 7 | EA-00434-0 | Clip-3/8" spring |
| 8 | EA-00608-0 | Grammet / rubber |
| 9 | CA-13214-0 | Plate |
| 10 | EA-00594-0 | Thermostat-HI-Limit |
| 11 | SB-00828-0 | Screw 8-32X1/2" |
| 12 | TU3266 | Nut-brass 8-32 |

WIRE BOX ASSEMBLY

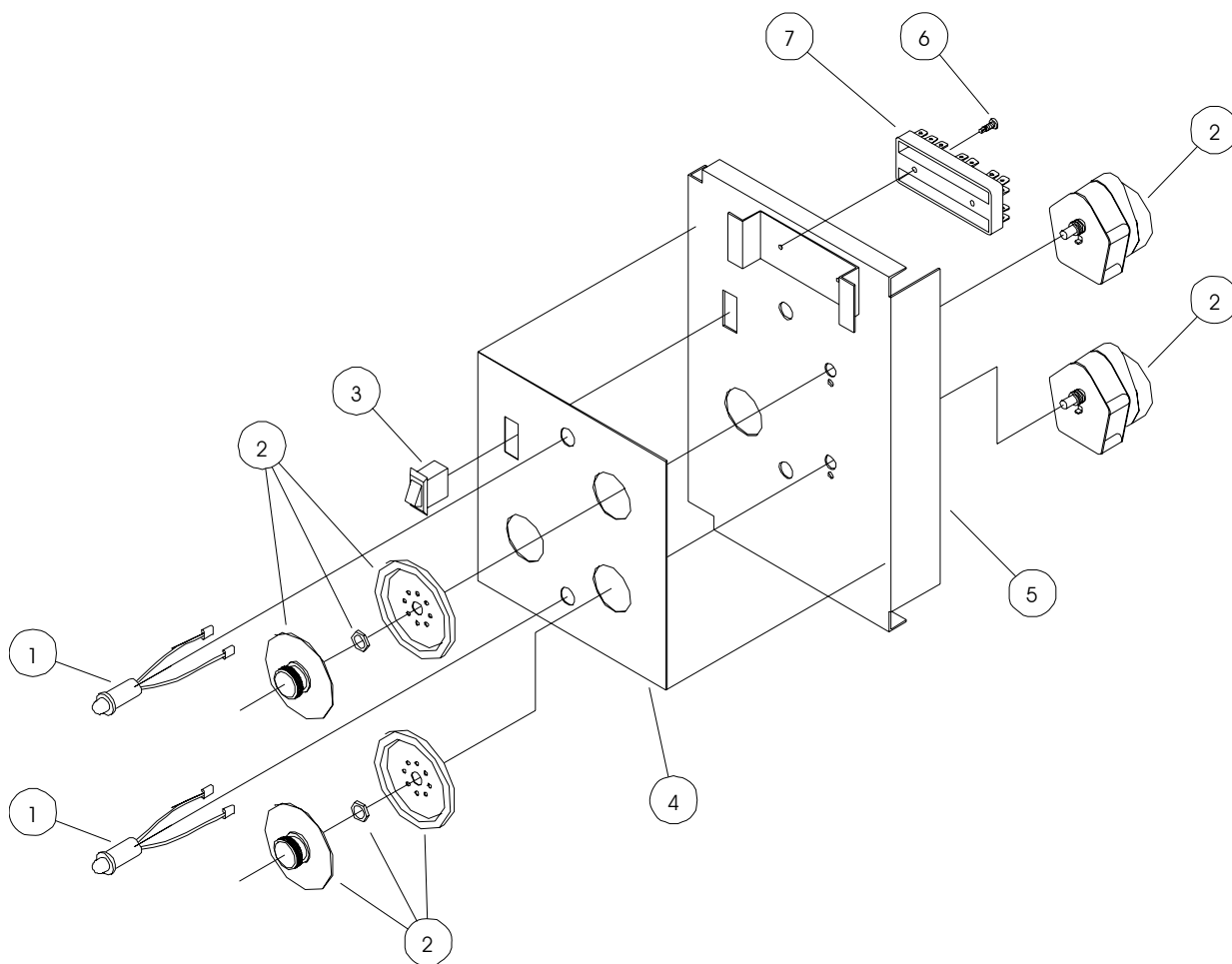

| Ref. Nb. | PartNo. | Description |
|----------|-------------|----------------------------------|
| | CSA-01608WH | Wireboxdoorassycomplete |
| 1 | TUT316 | Light LED24V |
| 2 | EA-11614-0 | Timer-manual 24V-60min. complete |
| 3 | EA-00619-0 | Switch-start |
| 4 | CA-13170-0 | Overlay-dual timer non-rev |
| 5 | CSA-01608WH | Wireboxdoorassy. |
| 6 | SB-00865-0 | Screw-selfdrilling#6-20X12" |
| 7 | EA-00210-0 | Terminalblock |
| 8 | ESA-00967-0 | Wireharness (not shown) |
| 9 | SB-00868-0 | Bushing7/8" |

DOOR ASSEMBLY

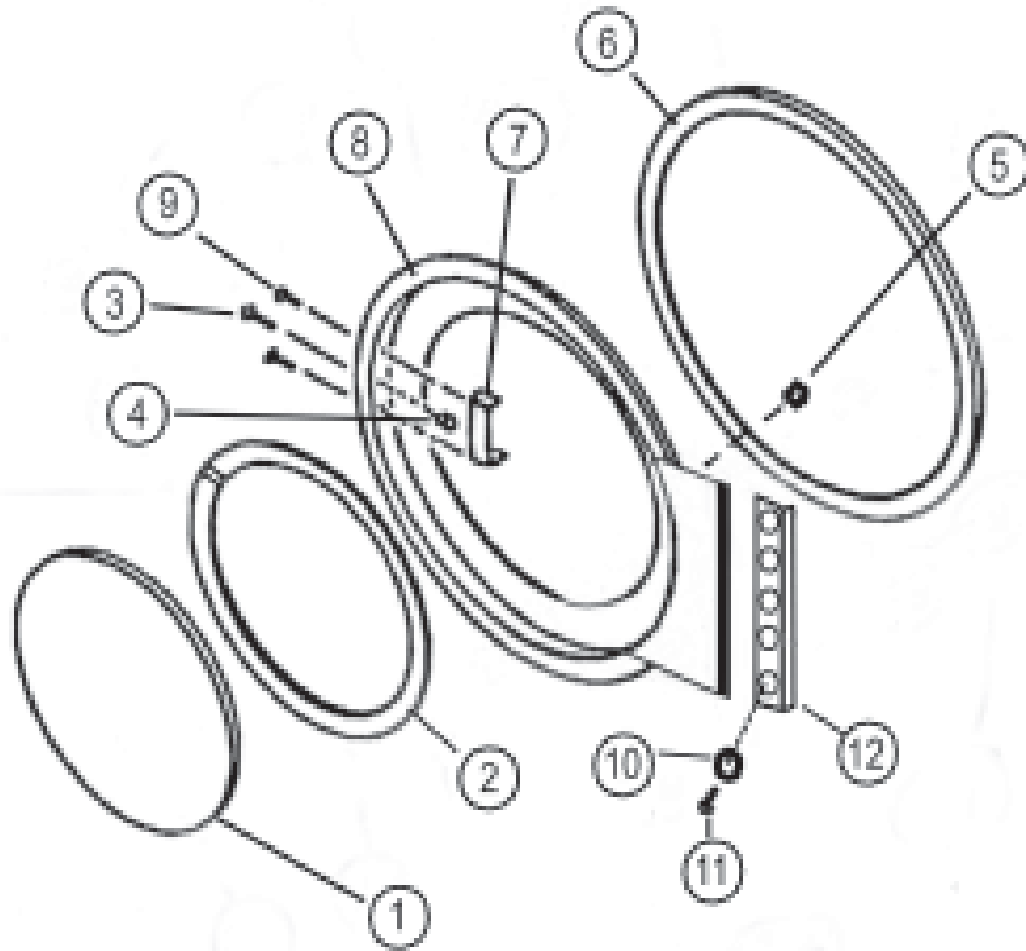

| Ref. No. | Part No. | Description |
|----------|----------|-------------|
|----------|----------|-------------|

| | | |
|--|-------------|--|
| | MSD-00864WH | Completed doorassy (consists of items 1 thru 9 only) |
|--|-------------|--|

| | | |
|----|--------------|--------------------------------|
| 1 | MD-00362-0 | Door Glass-clear |
| 2 | MD-00354-0 | Gasket-door glass-straight |
| 3 | TU3163 | Catch Pin |
| 4 | TU4840 | Crown nut |
| 5 | MD-00337-0 | Magnet-readswitch |
| 6 | MD-00338-0 | Gasket-door rim |
| 7 | TU2874 | Basket door handle |
| 8 | MSD-00858-WH | Basket door |
| 9 | TU3215 | Screw #10-32 X 3/8" |
| 10 | SB-00852-0 | Washer 1/4" external star lark |
| 11 | SB-00921-0 | Screw 1/4"-20 round head |
| 12 | MD-00348-0 | Hinge spacer |

LINT DOOR ASSEMBLY

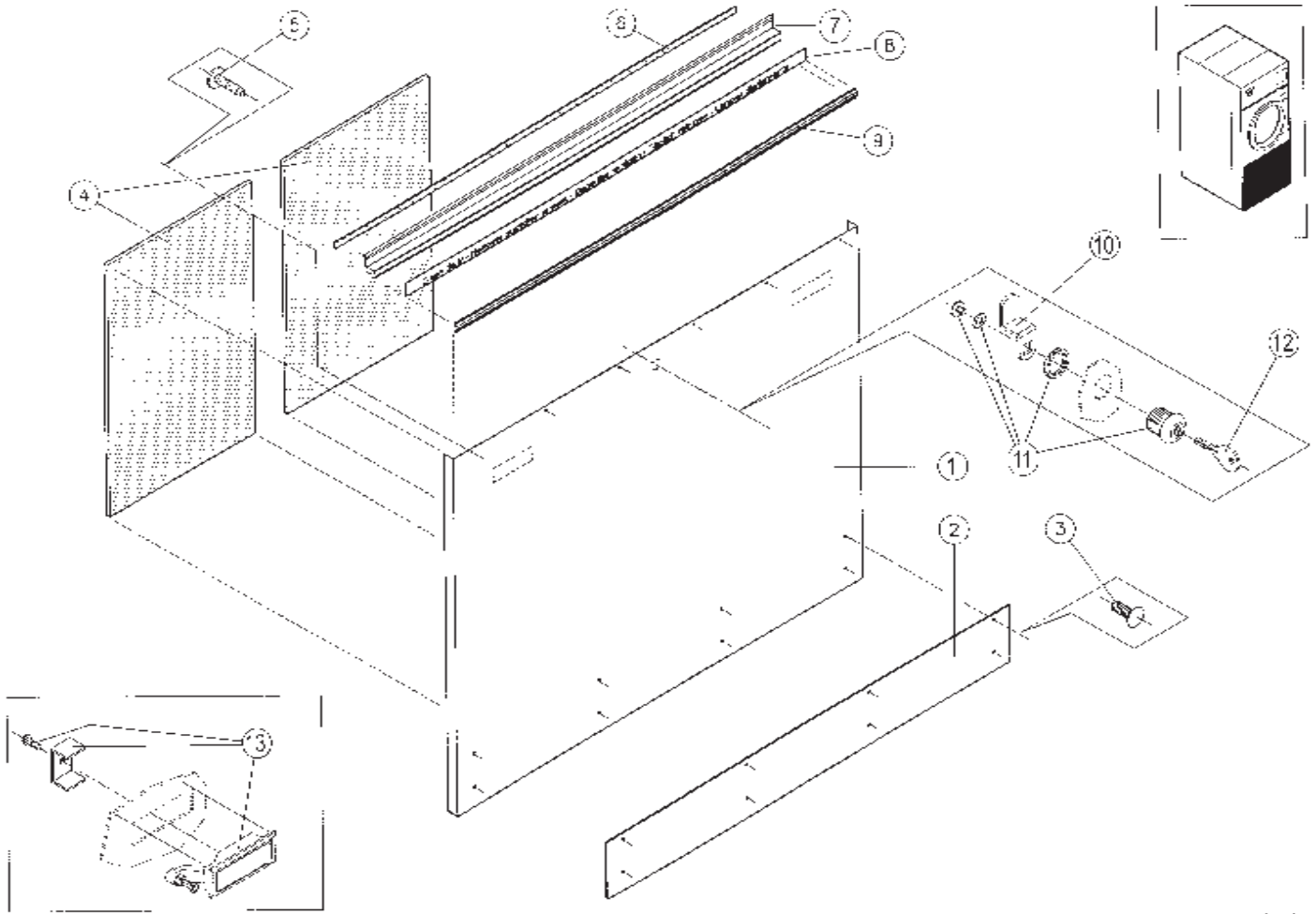

For OPL models only.

| Ref. No. | PartNo. | Description |
|----------|-------------|---------------------------------|
| | CSA-01515WH | Complete Asm - WMC75 OPL |
| | CSA-01594WH | Complete Asm - WMC75 Coin |
| 1 | CSA-01516WH | Lintdoorw/latchholes(white) OPL |
| 1 | CSA-01593WH | Lintdoorw/lockholes(white) Coin |
| 2 | CSA-00839-0 | Kickplate |
| 3 | SB-00949-0 | Fastenerplastickickplate |
| 4 | CA-13131-0 | InsulationlowerfrontpanelWMC75 |
| 5 | SB-00915-0 | Screwselfdrilling#10-16X5/8 |
| 6 | TU2853 | Gasket |
| 7 | CA-00697-0 | Handlelintdoor |
| 8 | CA-00841-0 | Label (notpartofassy.) |
| 9 | CA-00655-0 | Trim-rubrail-specify39"long |
| 10 | CA-11359-0 | CamLock |
| 11 | CA-00121-0 | Lock |
| 12 | CA-00119-0 | Key |
| 13 | CA-00123-0 | Latch-trigger |

BASKET & SPIDER ASSEMBLY

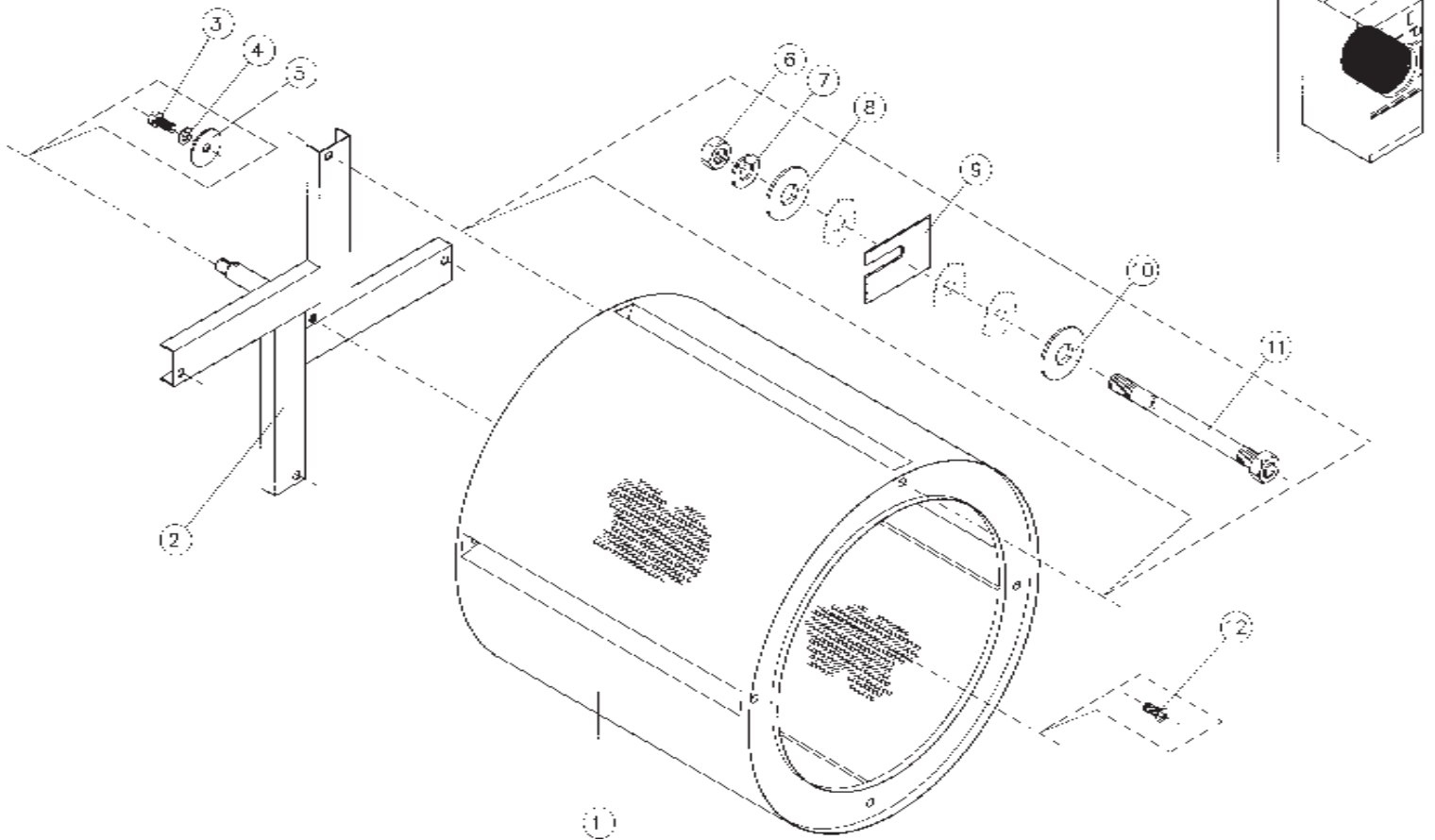

| Ref. Nb. | PartNb. | Description |
|----------|-------------|------------------------------------|
| | CSA-01592-0 | Basket & Spider Asm. WMC75 - S.S. |
| | CSA-01639-0 | Basket & Spider Asm. WMC75 - Galv. |
| 1 | CSA-01591-0 | Stainless steel basket assy. |
| 1 | CSA-01638-0 | Galvanized basket assy. |
| 2 | CSA-00729-0 | Spider assy. |
| 3 | TU5439 | Screw-cap 5/16-18 X 3/4" |
| 4 | TU2814 | Lockwasher 5/16" |
| 5 | SB-00843-0 | Washer fender 3/8" X 1 1/2" |
| 6 | SB-00906-0 | Nut 5/16" - 18 stover |
| 7 | TU2814 | Lockwasher 5/16" |
| 9 | TU7006 | Shim |
| 10 | CA-13208-0 | Basket ribs support |
| 11 | DA-11249-0 | Tierod |
| 12 | SB-009650-0 | Screw-button cap 5/16-18 |

REAR VIEW

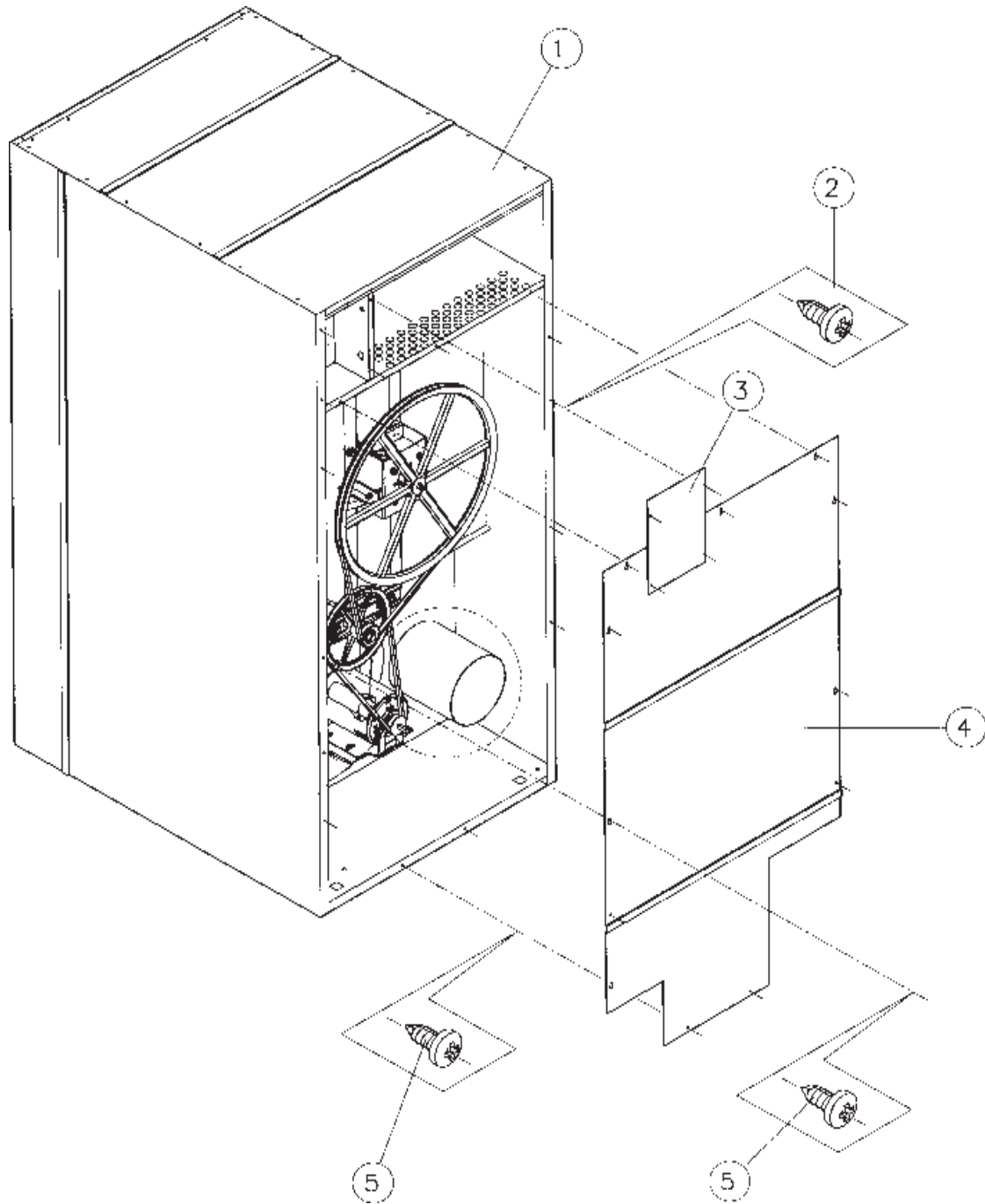

| Ref. Nb. | PartNb. | Description |
|----------|------------|----------------------------|
| 1 | CA-13027-0 | Toppanel |
| 2 | TU7733 | Screwselfdrilling8-18*1/2" |
| 3 | CA-11936-0 | Coverplate |
| 4 | CA-13018-0 | Backpanel |
| 5 | TU7733 | Screwselfdrilling8-18*1/2" |

AIR SWITCH ASSEMBLY

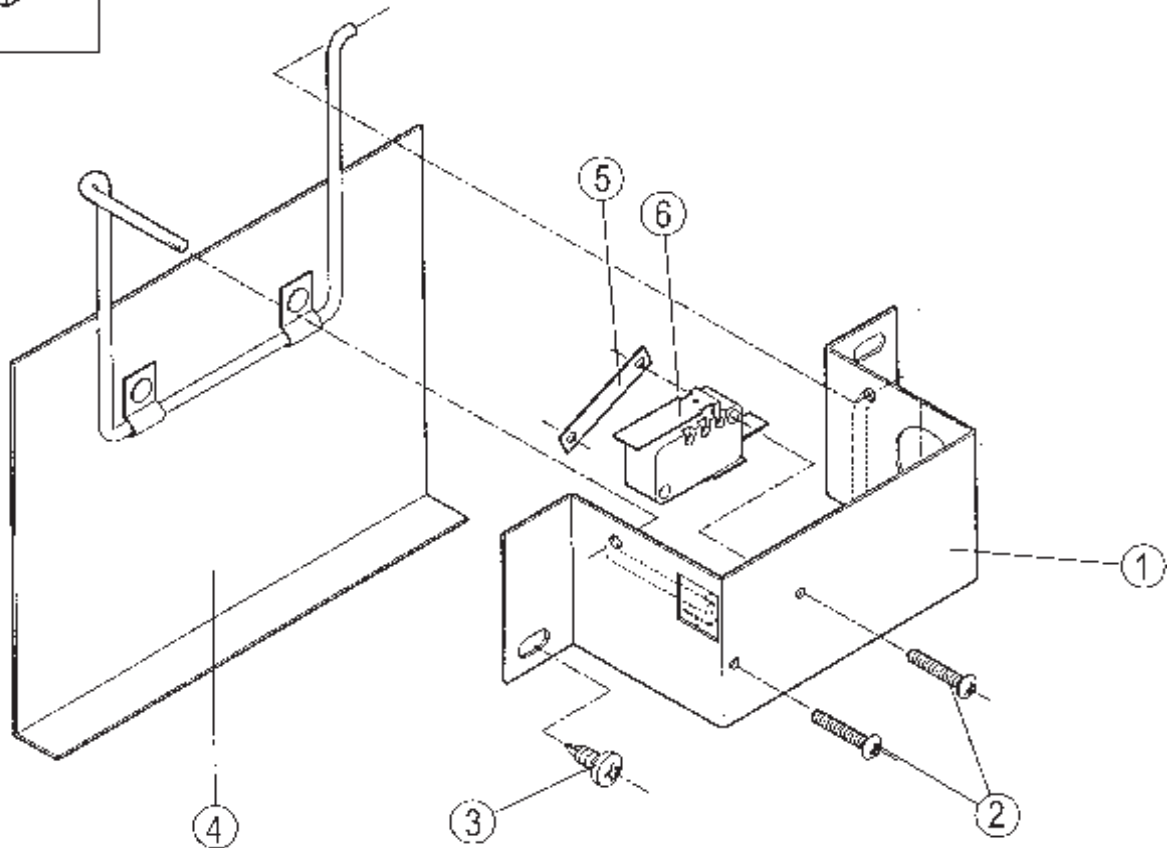
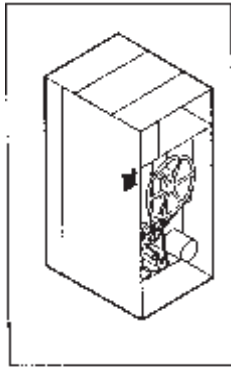

| Ref. Nb. | PartNb. | Description |
|----------|-------------|--------------------------------|
| | CSA-01334-0 | Sail switchassy. complete |
| 1 | CA-11854-0 | Bracket sail switch |
| 2 | SB-00955-0 | Screw phillips #4X3/4" |
| 3 | TU7733 | Screw selfdrilling 8-18*1/2" |
| 4 | CSA-01669-0 | Sail switch plate and rodassy. |
| 5 | SB-00954-0 | Clip twin-Timmerman |
| 6 | EA-00618-0 | Microswitch |

BASKET BEARINGS, SUPPORT, AND SHEAVE

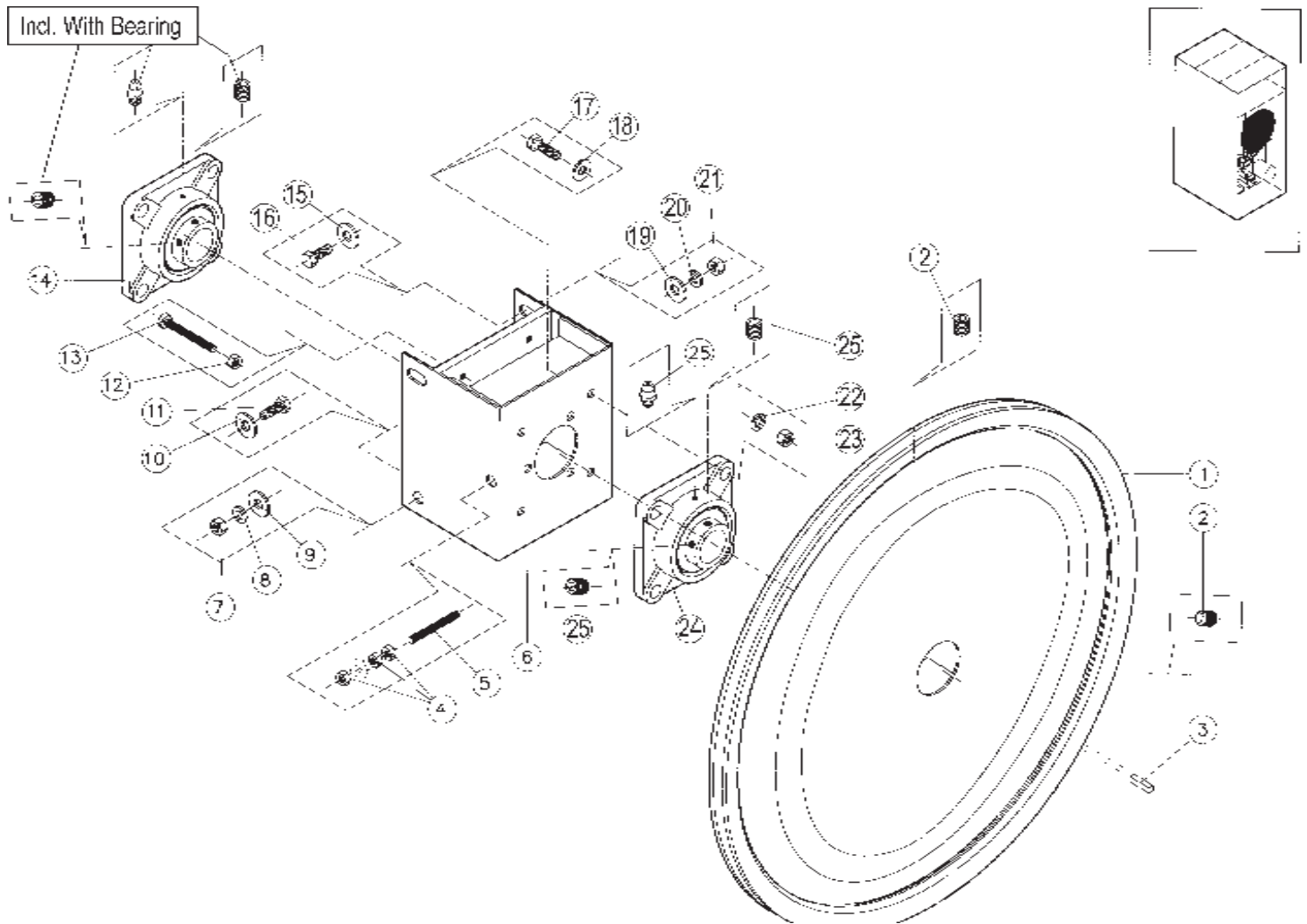

| Ref. Nb. | PartNo. | Description |
|----------|-------------|-------------------------|
| 1 | DA-11912-0 | Pulley-basket |
| 2 | | Part of pulley |
| 3 | DA-11914-0 | Key |
| 4 | C249 | Hexnut 5/16-18" |
| 5 | SB-00876-0 | Stud-5/16-18" |
| 6 | DSA-00719-0 | Bearing boxassy. |
| 7 | TU4787 | Hexnut 3/8-16" |
| 8 | VSB134 | Lock Washer 3/8" |
| 9 | IB140 | Washer 3/8" |
| 10 | IB140 | Washer 3/8" |
| 11 | IB139 | Screw 3/8-16*1-1/4" |
| 12 | C249 | Hexnut 5/16-18" |
| 13 | SB-00935-0 | Screw cap 5/16 - 18 X 3 |
| 14 | DA-00423-0 | Bearing flange 1-9/16" |

| Ref. Nb. | PartNo. | Description |
|----------|------------|----------------------|
| 15 | IB140 | Washer 3/8" |
| 16 | IB139 | Screw 3/8-16*1-1/4" |
| 17 | IB139 | Screw 3/8-16*1-1/4" |
| 18 | IB140 | Washer 3/8" |
| 19 | IB140 | Washer 3/8" |
| 20 | VSB134 | Lock Washer 3/8" |
| 21 | TU4787 | Hexnut 3/8-16" |
| 22 | VSB134 | Lock Washer 3/8" |
| 23 | TU4787 | Hexnut 3/8-16" |
| 24 | DA-00421-0 | Bearing-flange 13/8" |
| 25 | | Part of bearing |

MOTOR & FAN ASSEMBLY- NON-REVERSING

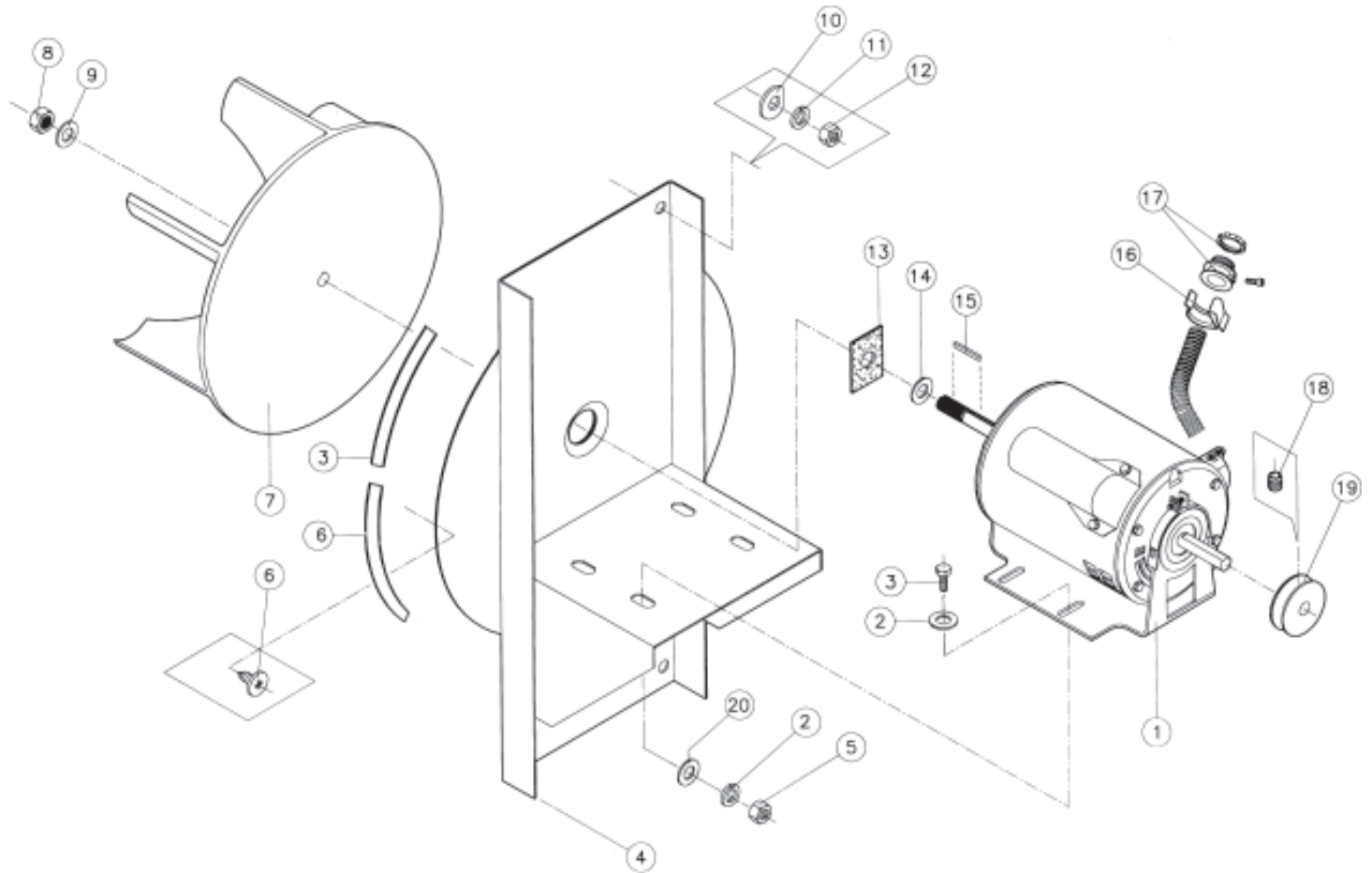

NO.

| | | |
|----|-------------|--|
| 1 | DA-00477-0 | Fanmotor 3/4HP115/208/230/60/50/1 |
| 1 | DA-00480-0 | Fanmotor 3/4 HP230/460/60/3&220/380/50/3 |
| 2 | TU2814 | Lockwasher 5/16" |
| 3 | TU5439 | Screw-cap 5/16-18X3/4" |
| 4 | DSA-00782-0 | Motormount w/a -non-rev. |
| 5 | SB-00842-0 | Nut, grip, Timmerman |
| 6 | SB-00836-0 | Screw, phillips, pancakehead |
| 7 | DSA-00773-0 | Fan (12") |
| 8 | SB-00813-0 | Nut 1/2-20" -Left hand thread |
| 9 | SB-00847-0 | Washer -1" O.D. X .505 I.D. |
| 10 | IB140 | Washer cut 3/8" |
| 11 | VSB134 | Washer lock 3/8" |
| 12 | TU4787 | Hexnut 3/8-16" |
| 13 | DA-00460-0 | Seal, acoustical |
| 14 | SB-00847-0 | Washer -1" O.D. X .505 I.D. |
| 15 | DA-00512-0 | Sheave, 60 cycle, 1/2" bore |
| 15 | DA-11906-0 | Sheave, 50 cycle, 1/2" bore |
| 16 | TU2473 | Gasket -curved (2req'd) |
| 17 | TU2474 | Gasket -straight (2req'd) |

IDLER ASSEMBLY

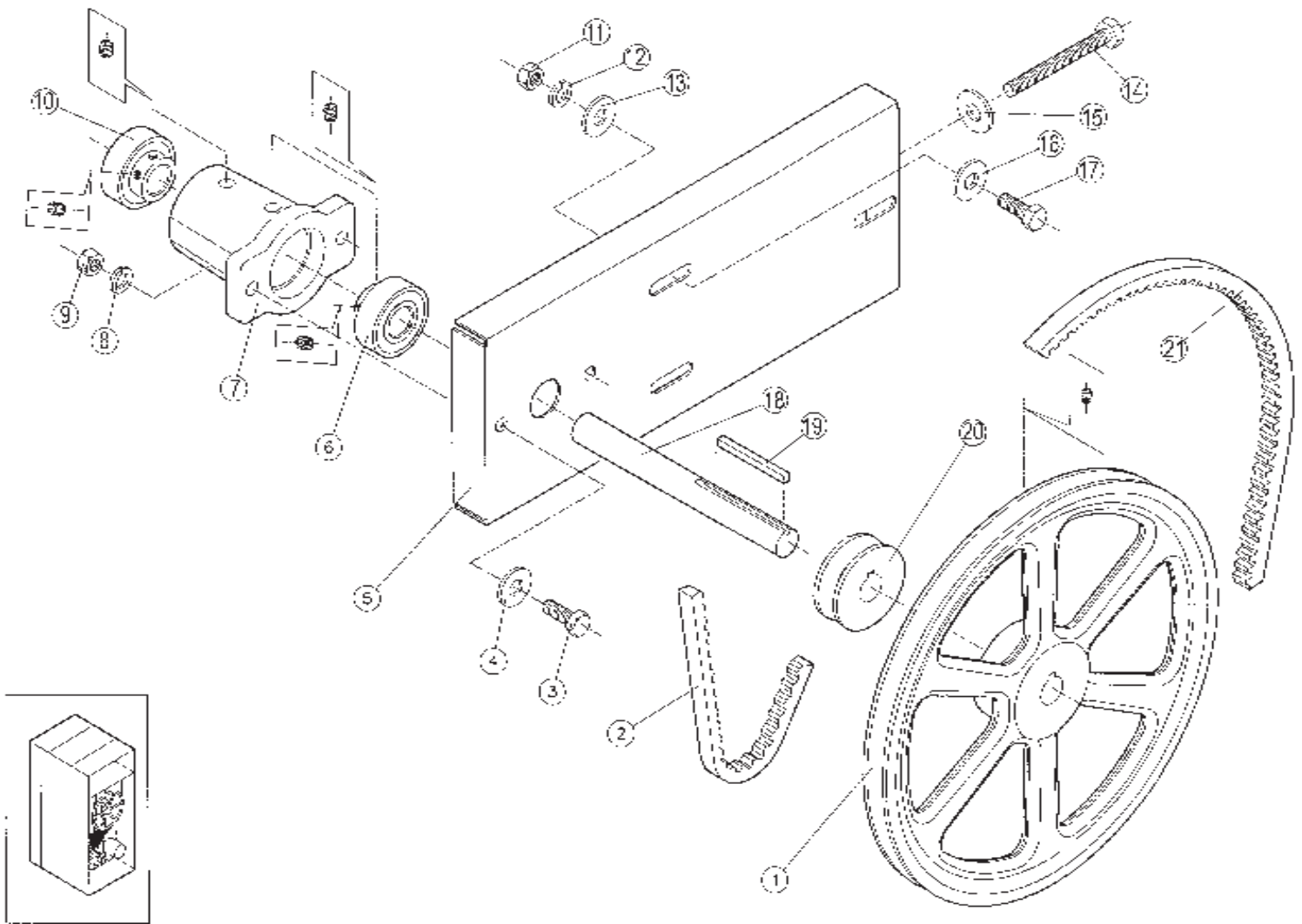

| Ref. No. | PartNo. | Description | Ref. No. | PartNo. | Description |
|----------|------------|-------------------------------|----------|--------------|--|
| 1 | DA-11904-0 | Idlerpulley11" | 11 | C249 | HexNut5/16-18" |
| 2 | DA-00497-0 | Basketbelt-non-reversing-AX71 | 12 | TU2814 | LockWasher 5/16" |
| 2 | DA-00497-0 | Basketbelt-reversing-AX71 | 13 | VSB130 | Washer 5/16" |
| 3 | FB124 | Screw5/16-18*1" | 14 | SB-00935-0 | Screw 5/16"-18X3" |
| 4 | VSB130 | Washer 5/16" | 15 | VSB130 | Washer 5/16" |
| 5 | CA-12059-0 | Idleradjustingplate | 16 | VSB130 | Washer 5/16" |
| 6 | DA-00518-0 | Bearing | 17 | TU5439 | Screw5/16-18*1" |
| 7 | DA-00517-0 | Housing-idlerbearing | 18 | DA-11711-0 | Idlershaft |
| 8 | TU2814 | Lock washer5/16" | 19 | TUD0187 | Key3/16square 2-1/2" |
| 9 | C249 | HexNut 5/16-18" | 20 | DA-11901-0 | V-beltpulley |
| 10 | DA-00518-0 | Bearing | 21 | DA-00525-0 | Belt-motortoidlerpulleyAX51 Non-reversing |
| | | | 21 | DA-0011908-0 | Belt-motortoidlerpulleyAX68 Reversing |

REAR CONTROL PANEL ASSEMBLY

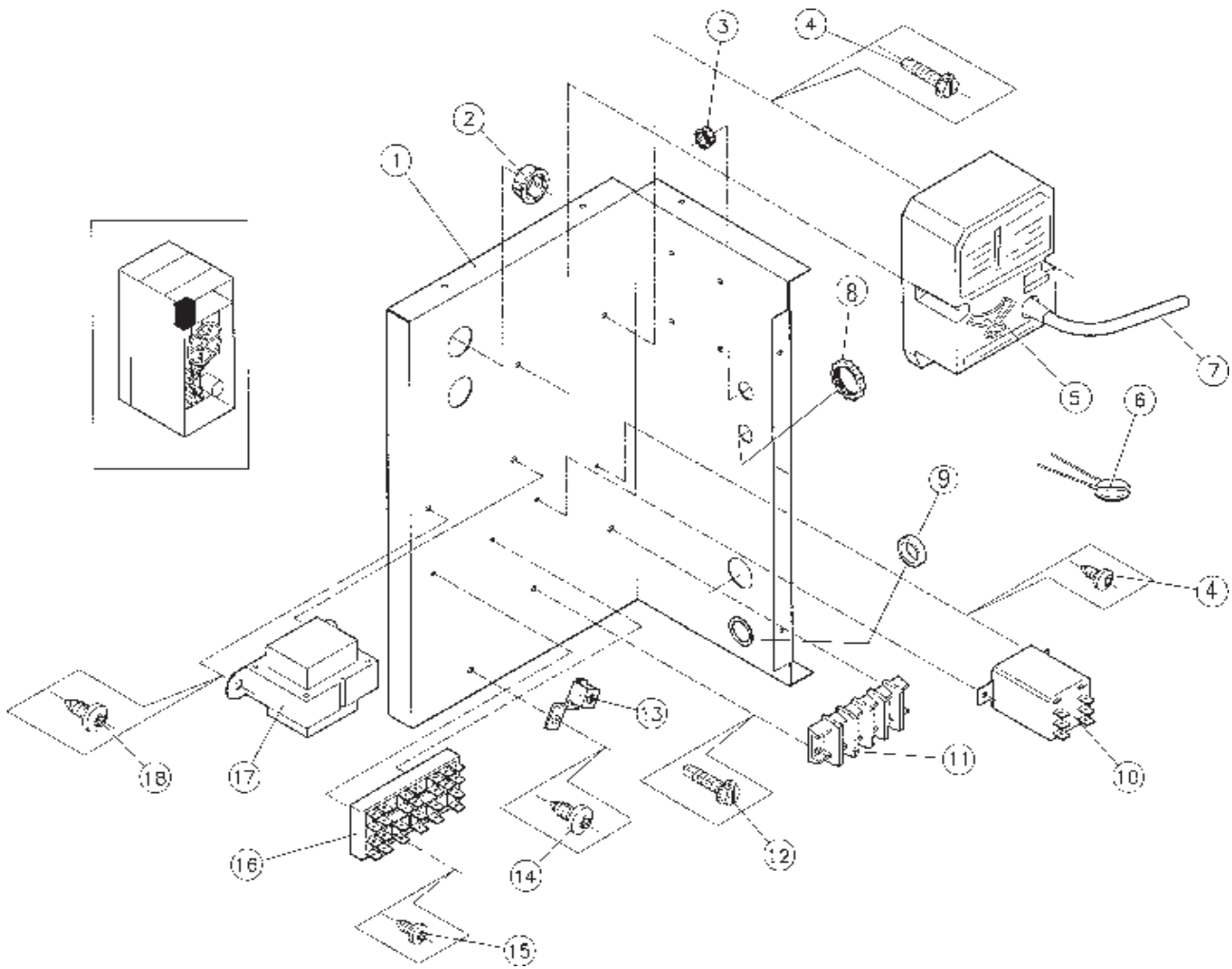

| Ref. Nb. | PartNo. | Description |
|----------|-------------|--|
| | ESA-00966-0 | Wireboxassy, rear, gas -115V-2 timer |
| | ESA-00974-0 | Wireboxassy, rear, gas -208/240V-2 timer |
| 1 | CA-11935-0 | Rear wiring box |
| 2 | SB-00868-0 | Bushing, insulating 7/8" |
| 3 | SB-00867-0 | Bushing, insulating 1/2" |
| 4 | TU7733 | Screw selfdrilling 8-18X1/2" |
| 5 | GA-00765-0 | Ignitor ram III DSI |
| 6 | EA-00651-0 | Varistor/relay/motor |
| 7 | GA-00803-0 | High voltage lead/ram |
| 8 | TU2490 | Plug button |
| 9 | EA-00680-0 | Knock-out plug |
| 10 | EA-11618-0 | Motor relay-3 pole-30 amp-24V |

| Ref. Nb. | PartNo. | Description |
|----------|------------|------------------------------|
| 11 | EA-00467-0 | Terminal block |
| 12 | TU7733 | Screw selfdrilling 8-18X1/2" |
| 13 | TU7738 | Ground lug |
| 14 | TU7733 | Screw selfdrilling 8-18X1/2" |
| 15 | SB-00865-0 | Screw selfdrilling 6-20X1/2" |
| 16 | EA-00210-0 | Terminal block |
| 17 | EA-00646-0 | Transformer 24V |
| 18 | TU7733 | Screw selfdrilling 8-18X1/2" |

GAS HEATING UNIT

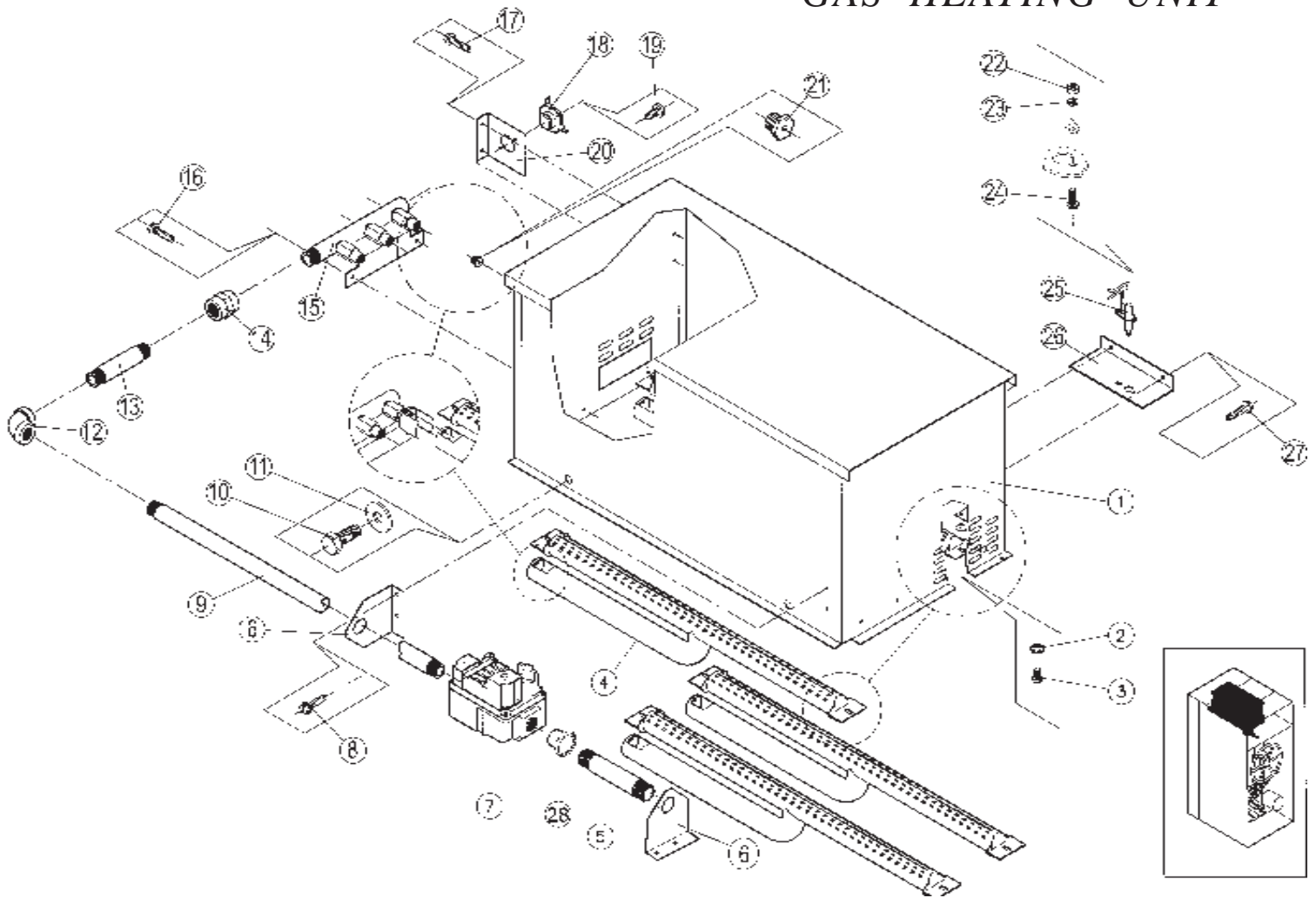

| Ref. No. | PartNo. | Description |
|----------|-------------|----------------------------|
| | GSA-0780-0 | Comp. assy. -Nat. gas |
| 1 | GSA-00767-0 | Housinggasburner |
| 2 | TU11613-0 | Lockwasher10external tooth |
| 3 | SB-00831-0 | Screw10-32*3/8" |
| 4 | GA-00756-0 | Gasburner |
| 5 | TU-4601 | Nipple-3/4"X3" |
| 6 | CA11878-0 | Bracket-pipe |
| 7 | GA-00770-0 | Gasvalve24V1/2" (Nat.gas) |
| 8 | TU7733 | Screwselfdrilling8-18X1/2" |
| 9 | TU7358 | Gaspipeline1/2X3/4" |
| 10 | TU5439 | Screwcap5/16-18X3/4" |
| 11 | VSB130 | Washer 5/16" |
| 12 | 390501053 | Elbow1/2" |
| 13 | OP308 | Nipple1/2"X5" |

| Ref. No. | PartNo. | Description |
|----------|-------------|----------------------------|
| 14 | OP314 | Union (gaspipeline) |
| 15 | GSA-00509-0 | Manifoldassy. |
| 16 | TU7733 | Screwselfdrilling8-18X1/2" |
| 17 | TU7733 | Screwselfdrilling8-18X1/2" |
| 18 | FA-00245-0 | ThermostatHILIMIT-330° |
| 19 | TU7733 | Screwselfdrilling8-18X1/2" |
| 20 | CA11028-0 | Bracketthermostat |
| 21 | GA-00761-0 | Gasorifice (specifysize) |
| 22 | TU3266 | Hexnut-brass8-32" |
| 23 | AT368 | Lockwasher #8 |
| 24 | M262 | Screwtrusshead8/32X3/8" |
| 25 | GA-11003-0 | Gasignitionelectrode |
| 26 | GA-10457-0 | Bracket |
| 27 | TU7733 | Screwselfdrilling8-18X1/2" |
| 28 | CA-13099-0 | Reducerpipe3/4" to1/2" |