



IPSO - USA

OWNER'S MANUAL

30 Lb. Stack Laundry Dryer



MODEL

GAS

DR30ST

IPSO-USA
3101 S. Haven Hwy. 77
Suite A
Panama City, FL 32405

Phone: (850)271-8486

THIS MANUAL MUST BE GIVEN TO THE EQUIPMENT OWNER.

MAN2030SI (ECN5667) 10/99

D0540

IMPORTANT NOTICES—PLEASE READ

For optimum efficiency and safety, we recommend that you read the Manual before operating the equipment. Store this manual in a file or binder and keep for future reference.



WARNING: Purchaser must post the following notice in a prominent location:



WARNING: For your safety the information in this manual must be followed to minimize the risk of fire or explosion or to prevent property damage, personal injury or death.

- Do not store or use gasoline or other flammable vapors or liquids in the vicinity of this or any other appliance.

- WHAT TO DO IF YOU SMELL GAS

- **Do not try to light any appliance.**
- **Do not touch any electrical switch; do not use any phone in your building.**
- **Clear the room, building or area of all occupants.**
- **Immediately call your gas supplier from a neighbor's phone. Follow the gas supplier's instructions.**
- **If you cannot reach your gas supplier, call the fire department.**

Installation and service must be performed by a qualified installer, service agency or the gas supplier.



WARNING: In the event the user smells gas odor, instructions on what to do must be posted in a prominent location. This information can be obtained from the local gas supplier.



WARNING: Wear safety shoes to prevent injuries.



WARNING: Purchaser must post the following notice in a prominent location:



FOR YOUR SAFETY

Do not store or use gasoline or other flammable vapors and liquids in the vicinity of this or any other appliance.



WARNING: A clothes dryer produces combustible lint and should be exhausted outside the building. The dryer and the area around the dryer should be kept free of lint.



WARNING: Be safe, before servicing machine, the main power should be shut off.

**ATTENTION: L'ACHETEUR DOIT PLACER L'AVERTISSEMENT
SUIVANT DANS UN ENDROIT CLAIR ET VISIBLE:**

AVERTISSEMENT. Assurez-vous de bien suivre les instructions données dans cette notice pour réduire au minimum le risque d'incendie ou d'explosion ou pour éviter tout dommage matériel, toute blessure ou la mort.

— Ne pas entreposer ni utiliser d'essence ni d'autres vapeurs ou liquides inflammables dans le voisinage de cet appareil ou de tout autre appareil.

— **QUE FAIRE SI VOUS SENTEZ UNE ODEUR DE GAZ:**

- Ne pas tenter d'allumer d'appareil.
- Ne touchez à aucun interrupteur. Ne pas vous servir des téléphones se trouvant dans le bâtiment ou vous vous trouvez.
- Evacuez la pièce, le bâtiment ou la zone.
- Appelez immédiatement votre fournisseur de gaz depuis un voisin. Suivez les instructions du fournisseur.
- Si vous ne pouvez rejoindre le fournisseur de gaz, appelez le service des incendies.

— l'installation et l'entretien doivent être assurés par un installateur ou un service d'entretien qualifié ou par le fournisseur de gaz.

**ATTENTION: L'ACHETEUR DOIT PLACER L'AVERTISSEMENT
SUIVANT DANS UN ENDROIT CLAIR ET VISIBLE:**

POUR VOTRE SECURITE

Ne pas entreposer ni utiliser d'essence ni d'autres vapeurs ou liquides inflammables dans le voisinage de cet appareil ou de tout autre appareil.



WARNING: To avoid fire hazard, do not dry articles containing foam rubber or similar texture materials. Do not put into this dryer flammable items such as baby bed mattresses, throw rugs, undergarments, (brassieres, etc.) and other items which use rubber as padding or backing. Rubber easily oxidizes causing excessive heat and possible fire. These items should be air dried.



WARNING: Synthetic solvent fumes from drycleaning machines create acids when drawn through the dryer. These fumes cause rusting of painted parts, pitting of bright or plated parts, and completely removes the zinc from galvanized parts, such as the tumbler basket. If drycleaning machines are in the same area as the tumbler, the tumbler's make-up air must come from a source free of solvent fumes.



WARNING: Do not operate without guards in place.



WARNING: Check the lint trap often and clean as needed but at least a minimum of once per day.



WARNING: Alterations to equipment may not be carried out without consulting with the factory and only by a qualified engineer or technician. Only **Manufacturer's** parts may be used.



WARNING: Remove clothes from dryer as soon as it stops. This keeps wrinkles from setting in and reduces the possibility of spontaneous combustion.



WARNING: Be safe - shut main electrical power and gas supply off externally before attempting service.



WARNING: Never use drycleaning solvents, gasoline, kerosene, or other flammable liquids in the dryer. ***FIRE AND EXPLOSION WILL OCCUR. NEVER PUT FABRICS TREATED WITH THESE LIQUIDS INTO THE DRYER. NEVER USE THESE LIQUIDS NEAR THE DRYER..***



WARNING: Do not place items exposed to cooking oils in your dryer. Items contaminated with cooking oils may contribute to a chemical reaction that could cause a load to catch fire.



WARNING: Never let children play near or operate the dryer. Serious injury could occur if a child should crawl inside and the dryer is turned on.



WARNING: Never tumble fiberglass materials in the dryer unless the labels say they are machine dryable. Glass fibers break and can remain in the dryer. These fibers cause skin irritation if they become mixed with other fabrics.



WARNING: Before operating gas ignition system - purge air from natural gas or propane gas lines per manufacturer's instructions.



WARNING: To reduce the risk of electric shock, disconnect this appliance from the power supply before attempting any user maintenance other than cleaning the lint trap. Turning the controls to the OFF position does not disconnect this appliance from the power supply.

IPSO DRYER WARRANTY

IPSO warrants all new equipment (and the original parts thereof) to be free from defects in material or workmanship for a period of two (2) years from the date of sale thereof to an original purchaser for use, except as hereinafter provided. With respect to non-durable parts normally requiring replacement in less than two (2) years due to normal wear and tear, and with respect to all new repair or replacement parts for IPSO equipment for which the two (2) year warranty period has expired, or for all new repair or replacement parts for equipment other than IPSO equipment, the warranty period is limited to ninety (90) days from date of sale. The warranty period on each new replacement part furnished by IPSO in fulfillment of the warranty on new equipment or parts shall be for the unexpired portion of the original warranty period on the part replaced.

With respect to electric motors, coin meters and other accessories furnished with the new equipment, but not manufactured by IPSO, the warranty is limited to that provided by the respective manufacturer.

IPSO's total liability arising out of the manufacture and sale of new equipment and parts, whether under the warranty or caused by IPSO's negligence or otherwise, shall be limited to IPSO-USA repairing or replacing, at its option, any defective equipment or part returned f.o.b. IPSO's factory, transportation prepaid, within the applicable warranty period and found by IPSO to have been defective, and in no event shall IPSO be liable for damages of any kind, whether for any injury to persons or property or for any special or consequential damages. The liability of IPSO does not include furnishing (or paying for) any labor such as that required to service, remove or install; to diagnose troubles; to adjust, remove or replace defective equipment or a part; nor does it include any responsibility for transportation expense which is involved therein.

The warranty of IPSO is contingent upon installation and use of its equipment under normal operating conditions. The warranty is void on equipment or parts; that have been subjected to misuse, accident, or negligent damage; operated under loads, pressures, speeds, electrical connections, plumbing, or conditions other than those specified by IPSO; operated or repaired with other than genuine IPSO replacement parts; damaged by fire, flood, vandalism, or such other causes beyond the control of IPSO; altered or repaired in any way that effects the reliability or detracts from its performance, or; which have had the identification plate, or serial number, altered, defaced, or removed.

No defective equipment or part may be returned to IPSO for repair or replacement without prior written authorization from IPSO. Charges for unauthorized repairs will not be accepted or paid by IPSO.

IPSO MAKES NO OTHER EXPRESSED OR IMPLIED WARRANTY, STATUTORY OR OTHERWISE, CONCERNING THE EQUIPMENT OR PARTS INCLUDING, WITHOUT LIMITATION, A WARRANTY OF FITNESS FOR A PARTICULAR PURPOSE, OR A WARRANTY OF MERCHANTABILITY. THE WARRANTIES GIVEN ABOVE ARE EXPRESSLY IN LIEU OF ALL OTHER WARRANTIES, EXPRESSED OR IMPLIED. IPSO NEITHER ASSUMES, NOR AUTHORIZES ANY PERSON TO ASSUME FOR IT, ANY OTHER WARRANTY OR LIABILITY IN CONNECTION WITH THE MANUFACTURE, USE OR SALE OF ITS EQUIPMENT OR PARTS.

For warranty service, contact the distributor from whom the IPSO equipment or part was purchased. If the distributor cannot be reached, contact IPSO.

IDENTIFICATION NAMEPLATE









The identification nameplate is located on the rear wall of the dryer. It contains the dryer serial number, product number, model number, electrical specifications and other important data that may be needed when servicing and ordering parts, wiring diagrams, etc. Do not remove this nameplate.

TABLE OF CONTENTS
30 LB. STACK LAUNDRY DRYER

PAGE	PAGE		
Model Numbers & Company Address	1	Bearing Replacement Instructions	33
Important Notices	2-4	Basket Alignment	34
Dryer Warranty	5	Basket Shimming Instructions	35
Table of Contents	6	Air Switch Adjustment	36
Warnings, Cautionary Notes and Symbols	7-8	Tumbler Assembly	37
Unpacking and General Installation	9	Door Assembly	38
Dryer Outline Dimensions (Illustration)	10	Control Panel Cover	39
Specifications	11	Lint Drawer Assembly	40
General Information and Motor List	12	Front Panel	41
Grounding Instructions	13	Coin Control	42
Gas Piping and Gas Loop Piping Installation	14-16	OPL Control	43
Gas Pipe Size Chart	17	Basket Assembly	44
Exhaust Installation-Multiple Manifold Duct	18	Rear	45
Exhaust Installation with Separate Exhaust	19	Power Box	46
Dryer Make-Up Air Requirements	20	Basket Support	47
Exhaust and Venting	21	Motor Assembly	48
Rules for Safe Operation	22	Air Switch Assembly	49
Operating Instructions-Coin Meter	23-24	Idler Assembly	50
Service Savers	25	Rear Control Box	51
Troubleshooting	26-29	Bonnet Assembly	52
Spark Ignition System	30-31		
General Maintenance	32		





SYMBOLS

The following symbols are used in this manual and/or on the machine.

Symbol	Description
	NOTE!
	Hot! Do Not Touch Heiß! Nicht Berühren Haute temperature! Ne pas toucher Caliente! no tocar Heet! Niet Aanraken
	dangerous voltage tension dangereuse Gefährliche elektrische Spannung tension peligrosa
	on marche Ein conectado
	off arrêt Aus desconectado
	start demarrage Start arranque de un movimiento
	emission of heat in general émission de chaleur en general Warmeabgabe allgemein emisión de calor
	cooling refroidissement Kühlen enfriamiento

SYMBOLS

The following symbols are used in this manual and/or on the machine.

Symbol	Description
	rotation in two directions rotation dans les deux sens Drehbewegung in zwei Richtungen movimiento rotativo en los dos sentidos
	direction of rotation sens de mouvement continu de rotation Drehbewegung in Pfeilrichtung movimiento giratorio o rotatorio en el sentido de la flecha
	End of Cycle
	caution attention Achtung atencion; precaucion

Unpacking/General Installation (All Dryers)

UNPACKING

Upon arrival of the equipment, any damage in shipment should be reported to the carrier immediately.

Upon locating permanent location of a unit, care should be taken in movement and placement of equipment.

See outline clearance diagrams for correct dimensions.

Remove all packing material such as: tape, manuals, skid, etc.

Leveling: Use spirit level on top of dryer. Adjust leveling bolts on dryer (see adjustable leveling bolts in maintenance section).

Check voltage and amperes on rating plate before installing the dryer.

The construction of the dryers permits installation side-by-side to save space or to provide a wall arrangement. Position dryer for the least amount of exhaust piping and elbows, and allow free access to the rear of dryer for future servicing of belts, pulleys and motors. Installation clearance from all combustable material is 0" ceiling clearance for the first 4" (102 mm) from the front of the dryer. After the first 4" (102 mm), the ceiling clearance required is 6" (153 mm). The rear clearance required is 6" (153 mm), and the side clearance is 0".

Before operating dryer, open basket door and remove blocking between front panel and basket. Read the instruction tags, owner's manual, warnings, etc.

**GENERAL
INSTALLATION (ALL
DRYERS)**

IMPORTANT

Opening the clothes loading door deactivates the door switch to shut off the motors, fan, gas, steam, or electric element. To restart the dryer, close the door and press in the push to start button and hold briefly.

IMPORTANT

This dryer is designed for a capacity maximum load. Overloading it will result in long drying times and damp spots on some clothes.

IMPORTANT

Maximum operating efficiency is dependent upon proper air circulation. The lint screen must be kept cleaned daily to insure proper air circulation throughout the dryer.

IMPORTANT

Provide adequate clearance for air opening into the combustion chamber.

Outline Dimensions

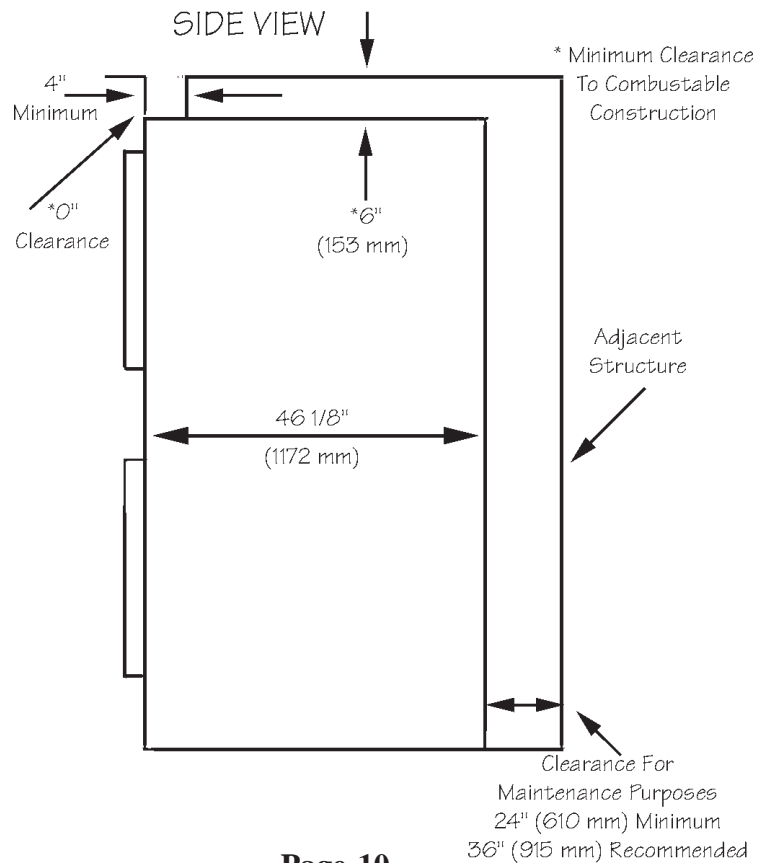
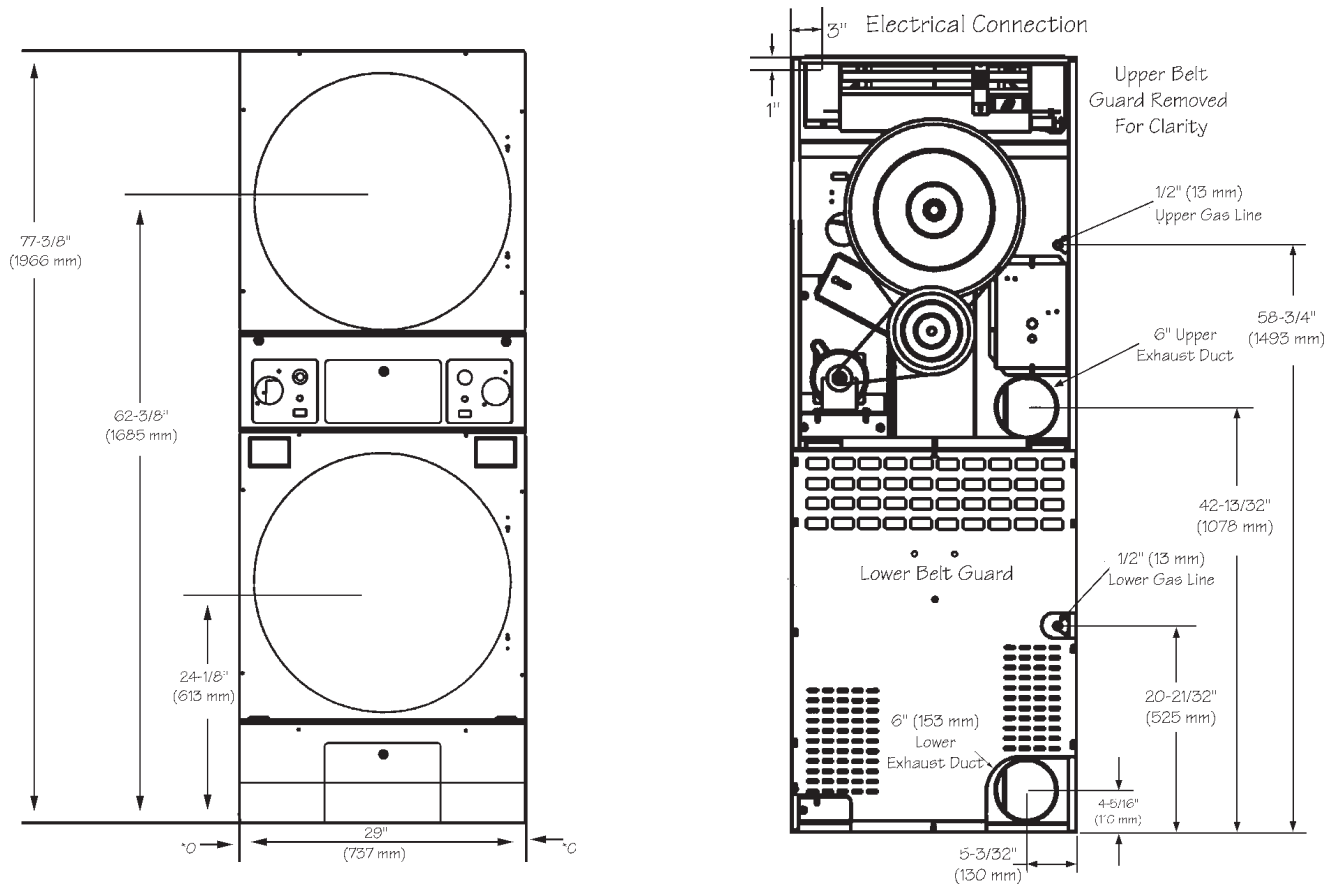

General Specifications

GENERAL SPECIFICATIONS

Motor Size.....	1/2 Hp (0.38 kW) per pocket
Basket Load Capacity	30 lb (14 kg) Dryweight per pocket
Basket Size	28" (712 mm) Diameter x 30" (762 mm) Deep (per pocket)
Door Opening	22 5/8" (575 mm)
Total Amps, Voltage, Cycle	Refer to rating plate on dryer
Cabinet Dimensions	29" (737 mm) W x 77 3/8" (1965 mm) H x 46-1/8" (1172 mm) D
Exhaust Air Duct Size	6" Diameter (152 mm) per pocket
Exhaust Air Flow	450 cfm (765 m ³ /h) per pocket
*Btu Input	80,000 Btu per hour per pocket (20,160 kcal/h) (Natural or LP gases)
Gas Pressure	6" (15 mbar)-12" (30 mbar) WC input (nat. gas) 3.5" (8.7 mbar) WC manifold press. (nat. gas) 10.5" (26.2 mbar) WC manifold press. (LP gas)
Gas Supply	1/2" NPT (DN15) 2 pipe connections
Electronic Ignition.....	Direct spark ignition system
Net Weight (approx.)	858 lb (389 kg)
Domestic Shipping Weight	908 lb (412 kg) (1 carton) (approx.)
Export Shipping Weight	983 lb (446 kg) (1 box) (approx.)
Export Shipping Dimensions	31" (787 mm) W x 48 1/8" (1222 mm) D x 82 3/8" (2092 mm) H
Export Cube	71 ft ³ (2 m ³)

* Input ratings as shown are for elevations up to 2000 ft. (610 m). For elevations above 2000 ft. (610 m), ratings should be reduced 4% for each 1000 ft. (305 m) above sea level.

General Information

GENERAL INFORMATION

The dryer is so designed that when an operator opens the dryer door, the basket and exhaust fan stops. You can expect fast drying from a laundry dryer. Hot, dry air is properly and effectively moved through the basket and exhausted through a lint trap to the atmosphere. The dryer comes equipped with a front accessible, easy cleaning lint drawer.

DRYER COOL-DOWN

Permanent press, durable press and other modern day fabrics require the care that your laundry dryers now provide.

At the end of the drying cycle, a timed “cool-down” control automatically takes over and continues the rotation of the fan and basket without heat until the garment load reaches a safe cool temperature. This function is performed at the end of each drying cycle and continues for two minutes.

Main Drive Motors

<u>Motor No.</u>	<u>Voltage</u>	<u>Hz.</u>	<u>Phase</u>	<u>HP</u>	<u>kW</u>	<u>Amps</u>	<u>RPM</u>
DA-00428-0	115/208-230	50	1	1/2	.38	9.2/4.6	1425
DA-00428-0	115/208-230	60	1	1/2	.38	8.0/4.0	1725
DA-00447-0	220-240/380-415	50	3	1/2	.38	2.2/1.1	1425
DA-00447-0	208-230/460	60	3	1/2	.38	1.9/1/0	1725

Grounding Instructions (Illustration)

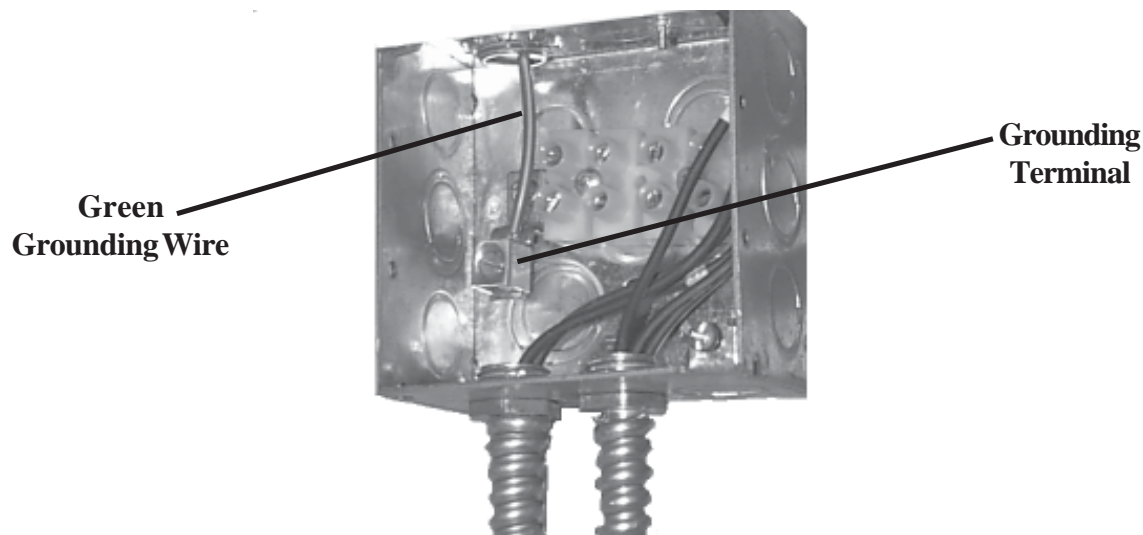

ELECTRICAL CONNECTIONS

Dryers must be electrically grounded by a separate #14 or larger green wire from the grounding terminal within the service connection box to a cold water pipe, or through the fourth green wire properly grounded and connected to the grounding terminal. In all cases, the grounding method must comply with local electrical code requirements; or in the absence of local codes, with the *National Electrical Code, ANSI/NFPA 70 or the Canadian Electrical Code, CA C22.1*.

See wiring diagram furnished with dryer. Your Cissell dryer is completely wired at the factory and it is only necessary for the electrician to connect the power leads to the wire connectors within the service connection box on the rear of the dryer. Do not change wiring without consulting factory as you may void the factory warranty. Do not connect the dryer to any voltage or current other than that specified on the dryer rating plate. (Wiring diagram is located on rear wall of dryer.)

ELECTRICAL CONTROLS SERVICING

CAUTION: Label all wires prior to disconnection when servicing controls. Wiring errors can cause improper and dangerous operations.

Verify proper operation after servicing.

«Attention. Lors des opérations d'entretien des commandes, étiqueter tous les fils avant de les déconnecter. Toute erreur de câblage peut être une source de danger et de panne»

**GAS PIPING
INSTALLATION**

1. The installation must conform with local codes, or in the absence of local codes with the *National Fuel Gas Code, ANSI Z223.1* or the *CAN/CGA-B149, Installation Codes*.
2. Check identification nameplate for type of gas for dryer.
3. Check the altitude of dryer.
4. Check with utilities company for proper gas pressure and gas supply line.
5. Natural gas only—check the gas pressure inlet supply to dryer, 10.5 inches water column (26.2 mbar) maximum. Manifold pressure—3.5 inches water column (8.8 mbar) pressure.
6. L.P. gas only—check the gas pressure inlet supply to dryer, 13 inches water column (32.4 mbar) maximum. Manifold pressure—10.2 inches water column (25.4 mbar) pressure.
7. A minimum 1/8 - inch NPT plugged tapping, accessible for tests gage connection, must be installed immediately upstream of the gas supply connection to the dryer.

CAUTION: Low gas pressure and intermittent gas will cause gas ignition problems and inadequate drying of laundry.

Gas Piping Installation (Illustration)

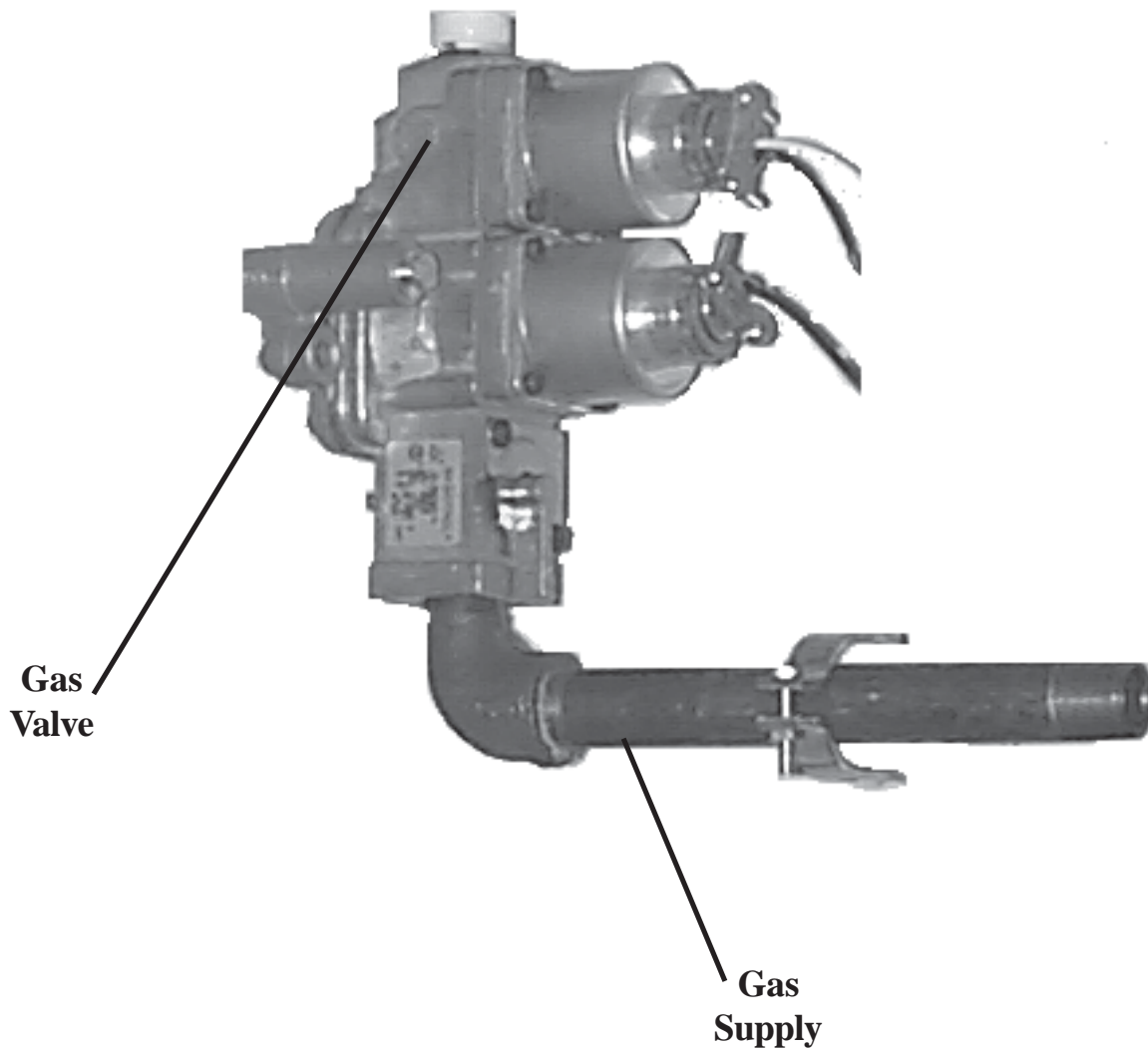

The dryer and its individual shutoff valve must be disconnected from the gas supply piping system during any pressure testing of that system at test pressures in excess of 1/2 psi (3.5 kPa).

The dryer must be isolated from the gas supply piping system by closing its individual manual shutoff valve during any pressure testing of the gas supply piping system at test pressures equal to or less than 1/2 psi (3.5 kPa).

Gas Service Installation Instructions

GAS SERVICE INSTALLATION INSTRUCTIONS

The size of the gas service pipe is dependant upon many variables, such as tees, lengths, etc. Specific pipe size should be obtained from the gas supplier. Refer to the "Gas Pipe Size" chart in this manual for general gas pipe size information.

CAUTION: Gas loop piping must be installed as illustrated to maintain equal gas pressure for all dryers connected to a single gas service

Other gas-using appliances should be connected upstream from the loop.

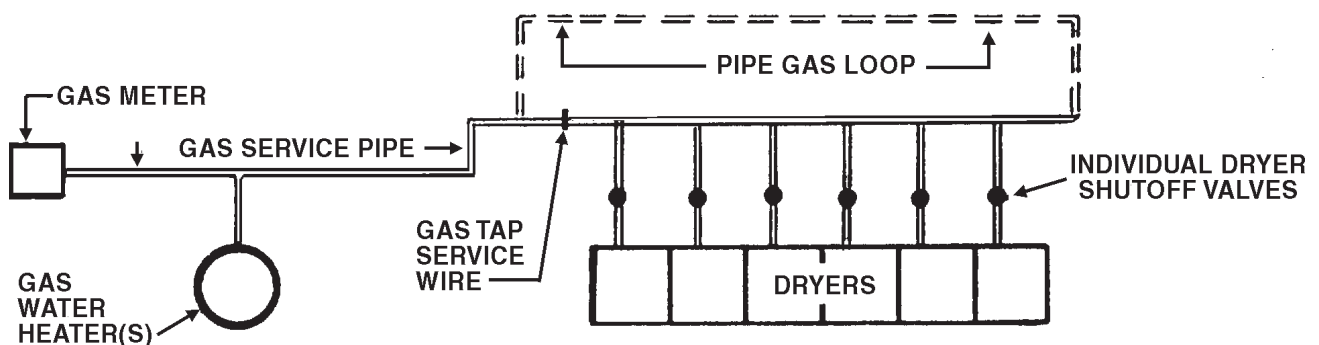

**WARNING:
LIQUIFIED PETROLEUM GASES ONLY!**

GAS PRESSURE REGULATOR FOR LIQUIFIED PETROLEUM GASES

A gas pressure regulator for liquified petroleum gases is not furnished on the gas heated clothes dryers. This regulator is normally furnished by the installer. In accordance with American Gas Association (AGA) and Canadian Gas Association (CGA) standards, a gas pressure regulator, when installed indoors, must be equipped with a vent limiter or a vent line must be installed from the gas pressure regulator vent to the outdoors.

Gas Pipe Size Chart

TOTAL BTU/HR (for LP Gas correct total BTU/HR below by multiplying by .6)	TOTAL KCAL	GAS PIPE SIZE FOR 1000 BTU (250 KCAL) NATURAL GAS AT 7" W.C. (17.5 MBAR) PRESSURE					
		In figuring total length of pipe, make allowance for tees and elbows.					
		(25 ft.) 7,62 m	(50 ft.) 15,24 m	(75 ft.) 22,86 m	(100 ft.) 30,48 m	(125 ft.) 38,1 m	(150 ft.) 45,72 m
60,000	15000	3/4	3/4	3/4	3/4	3/4	3/4
80,000	20000	3/4	3/4	3/4	1	1	1
100,000	25200	3/4	3/4	1	1	1	1
120,000	30200	3/4	1	1	1	1	1
140,000	35200	3/4	1	1	1	1	1 1/4
160,000	40300	3/4	1	1	1 1/4	1 1/4	1 1/4
180,000	45300	1	1	1	1 1/4	1 1/4	1 1/4
200,000	50400	1	1	1 1/4	1 1/4	1 1/4	1 1/2
300,000	75600	1	1 1/4	1 1/4	1 1/2	1 1/2	1 1/2
400,000	100800	1 1/4	1 1/4	1 1/2	1 1/2	1 1/2	2
500,000	126000	1 1/4	1 1/2	1 1/2	2	2	2
600,000	151200	1 1/2	1 1/2	2	2	2	2
700,000	176400	1 1/2	2	2	2	2	2 1/2
800,000	202000	1 1/2	2	2	2	2 1/2	2 1/2
900,000	230000	2	2	2	2 1/2	2 1/2	2 1/2
1,000,000	250000	2	2	2	2 1/2	2 1/2	2 1/2
1,100,000	270000	2	2	2 1/2	2 1/2	2 1/2	2 1/2
1,200,000	300000	2	2	2 1/2	2 1/2	2 1/2	2 1/2
1,300,000	330000	2	2 1/2	2 1/2	2 1/2	2 1/2	3
1,400,000	350000	2	2 1/2	2 1/2	2 1/2	3	3
1,500,000	380000	2	2 1/2	2 1/2	2 1/2	3	3
1,600,000	400000	2	2 1/2	2 1/2	3	3	3
1,700,000	430000	2	2 1/2	2 1/2	3	3	3
1,800,000	450000	2 1/2	2 1/2	3	3	3	3
1,900,000	480000	2 1/2	2 1/2	3	3	3	3
2,000,000	504000	2 1/2	2 1/2	3	3	3	3 1/2
2,200,000	550000	2 1/2	3	3	3	3 1/2	3 1/2
2,400,000	605000	2 1/2	3	3	3	3 1/2	3 1/2
2,600,000	650000	2 1/2	3	3	3 1/2	3 1/2	3 1/2
2,800,000	705000	2 1/2	3	3	3 1/2	3 1/2	3 1/2
3,000,000	750000	2 1/2	3	3 1/2	3 1/2	3 1/2	4
3,200,000	806000	3	3	3 1/2	3 1/2	3 1/2	4
3,400,000	850000	3	3 1/2	3 1/2	3 1/2	4	4
3,600,000	907000	3	3 1/2	3 1/2	3 1/2	4	4
3,800,000	960000	3	3 1/2	3 1/2	4	4	4
4,000,000	1000000	3	3 1/2	3 1/2	4	4	4

Multiple Vented Installation

Single dryer

Whenever possible, each stack dryer tumbler should have an individual short straight exhaust duct.

Multiple dryers

Whenever possible, each dryer tumbler in multiple installations should have individual short straight exhaust ducts.

If an individual or dual duct is not possible, install a long tapered main connector duct. A duct exceeding 20" (508 mm) should be a custom duct designed by a professional heating and air conditioner (HVAC) contractor.

Individual tumbler ducts should enter the main connector duct at a 45° angle in the direction of exhaust air flow.

The diameter of the main connector duct progressively increases as more dryers are added. (refer to illustration).

Testing

Back pressure of ducting system should not exceed 0.3 inch water column (.75 mbar) when all dryers are operating. Use a manometer for tests. More detailed ducting information can be obtained directly from your heating and air conditioning (HVAC) contractor or dealer.

Multiple vents

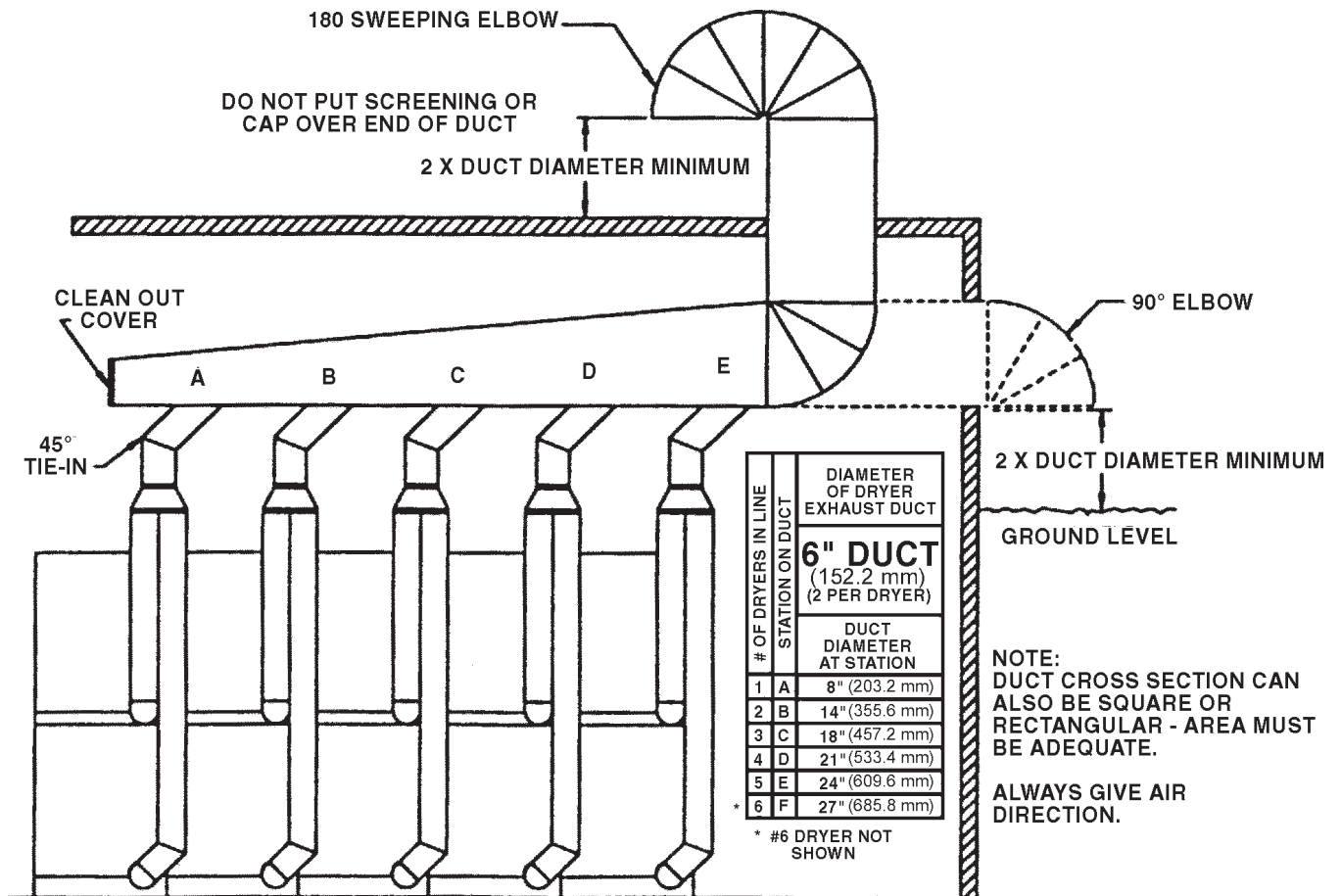

TYPICAL MULTIPLE VENTED INSTALLATION

Dryer Installation With Separate Exhaust (Preferred)

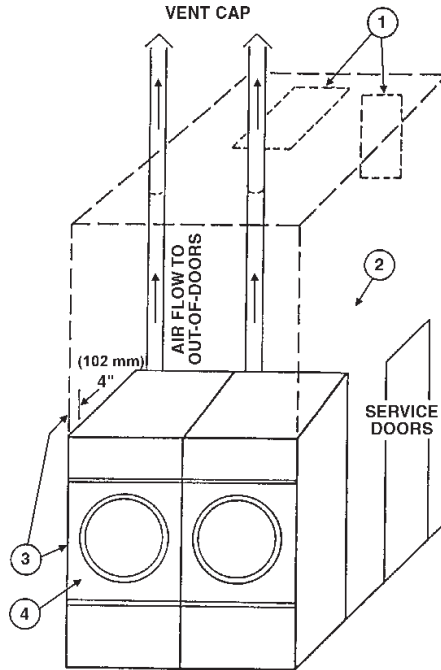

DRYER INSTALLATION WITH SEPARATE EXHAUST (PREFERRED)



For ductwork less than 14 feet (5) and 2 elbows equivalent and less than 0.3 inches (7.7 mm) static pressure:

NEVER exhaust the dryer into a chimney.

NEVER install wire mesh screen over the exhaust or make-up air area.

NEVER exhaust into a wall, ceiling, or concealed space.

1. Make-up air opening from outside the building may enter the enclosure from the top or side walls. (*See Dryer Make-Up Air Requirements Chart*)
2. Enclosure (plenum) with service door. This separates the dryer air from the room comfort air. If dryers use room air instead of outside air, additional heat loss can be another 25 Btu/h (6.3 kcal/h) for each cubic foot per minute (cfm) (.03m³/min.) used.
3. The installation clearance from all combustible material is 0" ceiling clearance for the first 4" (102 mm) from the front of the dryer. After the first 4" (102 mm), the ceiling clearance required is 6" (153 mm). The rear clearance required is 6" (153 mm) and the side clearance is 0".
4. Heat loss into laundry room from dryer front panels is about 60 Btu/h per square foot (15 kcal/h per 0.1m²).

Suggested Minimum Dryer Make-up Air Requirements

Dryer Model	Dryer Pocket Capacity		Maximum Air Flow Rate per Pocket		Duct Size For Service Connection		Required Make-up Air Area per Pocket	
	lb	kg	cfm	m3/h	inch	mm	sq. inch	cm2
C 30	30	13.6	700	1190	8	203	135	871
C 30 E/S	30	13.6	400	680	6	153	77	497
C 30 ST	30	13.6	450	765	6	153	87	561
C 50	50	22.7	800	1360	8	203	154	994
C 50 E/S	50	22.7	450	765	6	153	87	561
C 75	75	34	1000	1700	8	203	192	1239
C 75 E/S	75	34	536	911	6	153	103	665
C 75 ST	75	34	1000	1700	12	305	192	1239
HD80	80	36.3	1465	2490	10	254	282	1819
C 110	110	50	2200	3740	12	305	422	2723
C 110 E/S	110	50	850	1445	8	203	163	1052
C 125	125	56.7	2000	3400	12	305	384	2477
C 150	150	68	2250	3825	12	305	432	2787
HD175	175	79.4	2780	4726	12	305	534	3445
HD190	190	86.2	3000	5100	12	305	576	3716
WMC/HD20	20	9.1	450	765	6	153	87	561
WMC/HD30	30	13.6	625	1063	8	203	120	774
WMC/HD50	50	22.7	700	1190	8	203	135	871
WMC/HD75	75	34	750	1275	8	203	144	929

Notes:

- 1) The Model C 30 ST has 2 pockets per dryer, each pocket has the above listed characteristics; each pocket is exhausted separately with a 6" (153mm) duct.
- 2) The Model C 75 ST has 2 pockets per dryer, each pocket has the above listed characteristics; both pockets have one 8" (203mm) exhaust manifolded into one 12" (305mm) exhaust duct for exhaust connection.
- 3) For the C 30 ST and the C 75 ST Models, the Required Make-up Air Area shown in the table should be doubled since it is shown per pocket, only.
- 4) E/S indicates an Energy Saving Model.

Exhaust and Venting

DRYER AIR FLOW INSTALLATION

Nothing is more important than air flow for the proper operation of a clothes dryer. A dryer is a pump which draws make-up air from the out-of-doors, through the heater, through the clothes and then forces the air through the exhaust duct back to the out-of-doors. Just as in a fluid water pump, there must be a fluid air flow to the inlet of the dryer, if there is to be the proper fluid air flow out of the exhaust duct.

In summary, there must be the proper size out-of-doors inlet air opening (4-6 times the combined areas of the air outlet) and an exhaust duct, size and length of which allows flow through the dryer with no more than 0.3 inches water column (.75 mbar) static pressure in the exhaust duct.

In some instances, special fans are required to supply make-up air, and/or boost exhaust fans are required for both regular and energy saving models.

EXHAUST DUCT

FOR BEST DRYING:

1. Exhaust duct maximum length 14 feet (5 m) of straight duct and maximum of two 90° bends.
2. Use 45° and 30° elbows wherever possible.
3. Exhaust each dryer separately.
4. Use 2 feet (0.6 m) of straight duct on dryer before installing an elbow on energy-saver models only.
5. **Do not** install wire mesh or other restrictions in the exhaust duct.
6. Use clean-outs in the exhaust duct and clean periodically when needed. Examine the exhaust system at least once every three months, and more frequently if indicated.
7. **Never** exceed 0.3 inches water column (.75 mbar) static pressure in the exhaust duct.
8. Inside surface of the duct must be smooth.
9. Recommend pop rivets for duct assembly.

MAKE-UP AIR

FOR BEST DRYING:

1. Provide opening to the out-of-doors in accordance with the following:
For each dryer—
6 inches (153 mm) diameter exhaust requires a 1 square feet (0.1 m²) opening for make-up air.
8 inches (204 mm) diameter exhaust requires a 2 square feet (0.2 m²) opening for make-up air.
12 inches (305 mm) diameter exhaust requires a 4 square feet (0.4 m²) opening for make-up air.
2. Use barometric shutters in the inlet air opening to control air when dryers are not running.

OTHER RECOMMENDATIONS

Other Recommendations

To assure compliance, consult local building code requirements.

TROUBLESHOOTING

Troubleshooting

Hot dryer surfaces, scorched clothes, slow drying, lint accumulations, or air switch malfunction are indicators of exhaust duct and/or make-up air problems.

Rules for Safe Operation of Dryer

RULES FOR SAFE OPERATION OF DRYER

1. Be sure your dryer is installed properly in accordance with the recommended instructions.
2. **CAUTION**
Be safe—shut main electrical power supply and gas supply off externally before attempting service.
3. **CAUTION**
Never use drycleaning solvents: gasoline, kerosene, or other flammable liquids in the dryer. ***Fire and explosion will occur.***
Never put fabrics treated with these liquids into the dryer.
Never use these liquids near the dryer.
Always keep the lint screen clean.
Never use heat to dry items that contain plastic, foam or sponge rubber, or rags coated with oils, waxes or paints. The heat may damage the material or create a fire hazard. Rubber easily oxidizes, causing excessive heat and possible fire.
Never dry the above items in the dryer.
4. **Never** let children play near or operate the dryer. Serious injury will occur if a child should crawl inside and the dryer is turned on.
5. **Never** use dryer door opening and top as a step stool.
6. Read and follow manufacturer's instructions on packages of laundry and cleaning aids. Heed any warnings or precautions.
7. **Never** tumble fiberglass materials in the dryer unless the labels say they are machine dryable. Glass fibers break and can remain in the dryer and could cause skin irritation if they become mixed into other fabrics.
8. Reference: Lighting and shut-down instructions and wiring diagrams are located on the rear wall of the dryer cabinet.
9. The dryer must not be installed or stored in an area where it will be exposed to water and/or weather.

ENERGY-SAVING TIPS

1. Install dryer so that you can use short, straight venting. Turned elbows and long vent tubing tend to increase drying time. Longer drying time means the use of more energy and higher operating costs.
2. Operate dryer using full-size loads. Very large loads use extra energy. Very small loads waste energy.
3. Dry light-weight fabrics separately from heavy fabrics. You will use less energy and get more even drying results by drying fabrics of similar weight together.
4. Clean the lint screen area daily. A clean lint screen helps give faster, more economical drying.
5. **Do not** open the dryer door while drying. You let warm air escape from the dryer into the room.
6. Unload the dryer as soon as it stops. This saves having to re-start your dryer to remove wrinkles.

Operating Instructions—Coin Meter Models

OPERATING INSTRUCTIONS—COIN METER MODELS

OPERATING INSTRUCTIONS—COIN METER MODELS

1. After loading the dryer with water washed clothes, close the loading door.
2. **ELECTRO-MECHANICAL COIN METER:** Insert proper coin(s) in slot and turn knob until it stops.
COMPUTERIZED COIN METER: Insert coin. Amount of drying time will appear on the digital display. Maximum time is 99 minutes. Additional coins may be vended any time during the cycle.
3. Turn temperature fabric selection dial to desired setting:
HIGH—185° F (85° C) exhaust temperature, *heavy fabrics and hard to dry, (cottons and linens).*
MEDIUM—150°F (66° C) exhaust temperature, *permanent press, synthetic blends.*
LOW—135°F (58° C) exhaust temperature, *delicate, sheer fabrics.*
4. Press the “**Start**” button to start the drying and cooling cycles.

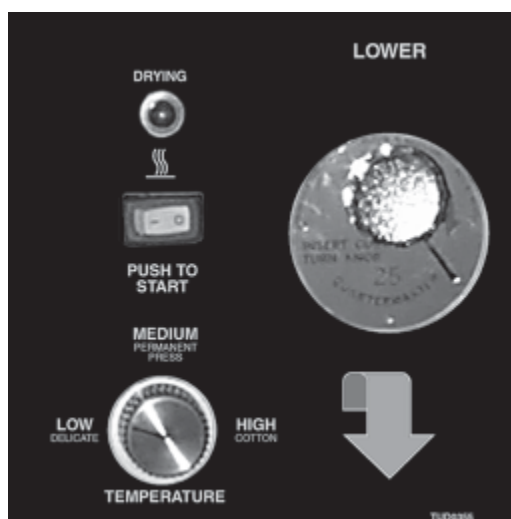

ELECTRO-MECHANICAL COIN METER

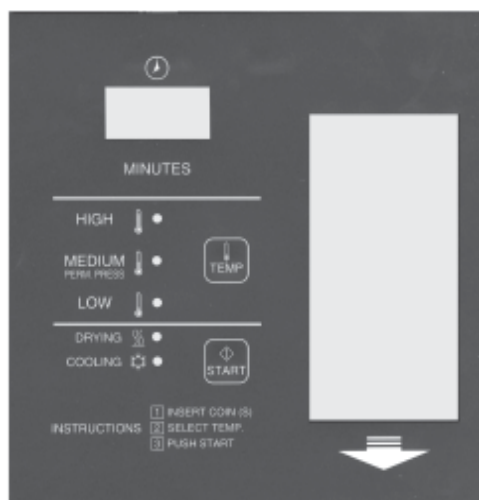

DMPSIMPLEMICROPROCESSOR

WHAT IS HAPPENING AFTER STEP 4:

1. Digital display will count down time remaining in cycle (computerized coin meter).
2. The fan motor and basket will revolve.
3. The heat source will be energized.
4. The heated air will mix with the wet clothes and evaporate the moisture.
5. The thermostats will operate at a safe temperature.
6. The heat will shut off and the cooling cycle will begin.

IMPORTANT

IMPORTANT

If the dryer door is opened during the drying cycle, the fan and heat will shut off. Press “**START**” button to resume the cycle.

This dryer is designed for a capacity maximum load. Overloading it will result in longer drying time and damp spots on some of the load.

Maximum operating efficiency depends on proper air flow. The lint screen must be kept clean daily to ensure proper circulation of air throughout the dryer.

This commercial dryer has keys for the lint door and access door to burners and controls. This is for the safety of the user.

Service Savers

TROUBLESHOOTING

To help you troubleshoot the dryer, listed below are the most common reasons for service calls and some answers to the problems. Before you call service, please review the following items:

DRYER WON'T START

DRYER WON'T START

1. Is the door completely closed?
2. Are the controls set to the “**on**” position?
3. Did you push the “**start**” control?
4. Has a fuse blown or a circuit breaker tripped?
5. Are the fuses tight?
6. Check for low voltage.
7. Has the bonnet thermostat (gas only) tripped? If so, push to reset.

DRYER WON'T HEAT

DRYER WON'T HEAT

1. Is the dryer set for “**cooling time**” rather than “**drying time**”?
2. Are the gas valves in the dryer and in the main gas line turned on?
3. Check for low or intermittent gas pressure.
4. Check spark ignition module diagnostic light.

CLOTHES ARE NOT SATISFACTORILY DRY

CLOTHES ARE NOT SATISFACTORILY DRY

1. *Timed cycle*—Did you allow enough heating time before the cool-down part of the cycle?
2. Is the lint screen blocked?
3. Is the exhaust duct to the outside clean and not blocked? (*A blocked exhaust will cause slow drying and other problems.*)

GAS DRYER IGNITION

GAS DRYER IGNITION

Refer to the page on “*Instructions for the Direct Ignition System Operation*”. Check to see if the manual gas valve is open. Then reset the dryer controls. All panels, covers, and doors must be in place and closed before starting the dryer.

VERY IMPORTANT

VERY IMPORTANT

When calling the factory for service, always refer to the model number and serial number.

Troubleshooting Chart

Troubleshooting Chart

TROUBLE	CAUSE	REMEDY
Motor will not start.	No power.	Check fuses on circuit breakers. Make sure main control switch is "on". Check bonnet thermostat (gas only).
	Incorrect power.	Check power source; voltage, phase and frequency must be the same as specified on electrical rating plate.
	Time off.	Check timer for proper setting or check coin meter for properly vending.
	Loose wiring connections.	Check wire connections in electrical box on rear of dryer.
	Loading door open.	Close door.
	Door switch out of adjustment.	Adjust switch by removing front panel and bend actuator lever to clear switch button 3/8" with front panel in place.
	Defective door switch.	Replace switch.
	Defective basket motor contactor.	Replace contractor.
	Tripped/defective safety thermostat on gas bonnet.	Reset/replace thermostat.
Motor tripping on thermal.	Low voltage.	Check voltage at motor terminals. Voltage must be within $\pm 10\%$ of voltage shown on motor rating plate. If not, check with local power company for recommended corrective measures.
	Inadequate wiring.	Check with local power company to insure that wiring is adequately sized for load.
	Loose connections.	Check all electrical connections and tighten any loose connections.
	Inadequate air.	Check installation sheet for recommended make-up air openings.
	Poor housekeeping.	Clean lint accumulation on and around motors.
Dryer does not stop at end of time period.	Defective timer.	Replace timer.
Motor runs but basket will not revolve.	V-belt broken.	Replace V-belt.
	V-belt loose.	Adjust belt tension.
	Motor pulley loose.	Tighten set screw.
	Basket overloaded.	Remove load.

Troubleshooting Chart

Troubleshooting Chart

TROUBLE	CAUSE	REMEDY
Dryer noisy or vibrating.	Not leveled.	Check manual for proper leveling procedures.
	Fan out of balance.	Accidental damage to the fan blade can change the dynamic balance. Damaged fans should be replaced.
	Basket rubbing.	Adjust basket clearance.
	V-belt sheaves.	Tighten set screws. Make sure sheaves are in proper alignment.
	Belt.	Adjust belt tension.
	Foreign objects.	Occasionally screws, nails, etc, will hang in the basket perforations and drag against the sweep sheets surrounding the basket. Such foreign objects should be removed immediately.
Dryer runs, but no heat.	Incorrect voltage.	Check for correct control voltage - 120V.
	No voltage.	Check power supply, check secondary voltage on transformer and check wiring and wiring diagram.
	Direct spark ignition module defective.	Replace direct spark ignition module.
	Defective gas valve.	Replace coil assembly.
	Gas turned off.	Turn manual gas valve on.
	Defective door switch.	Replace door switch.
	Air switch not operating.	Clean out lint compartment daily. Check back draft damper for foreign objects, lint accumulation or other causes that may prevent damper from opening. Check duct work for lint build-up. Check installation sheet to insure that duct work and make-up air openings are adequately sized. Check exhaust outlet. If a screen has been improperly installed on the outlet, it may be clogged with lint or frozen over in winter. NEVER install a screen on the exhaust outlet. Vacuum within dryer drops to .09 inches of water column (.23 mbar), or less, for normal operation of dryer. Vacuum reading (in inches of water) should range between .15 (.38 mbar) and .3 inches (.75 mbar). Vacuum reading can be made with a vacuum U-gauge by removing a sheet metal screw in the front panel of dryer and inserting the rubber tube of the vacuum gauge into screw opening.

Troubleshooting Chart

Troubleshooting Chart

TROUBLE	CAUSE	REMEDY
Dryer runs, but no heat. (continued)	Air switch out of adjustment.	See air switch adjustment sheet.
	Air switch defective.	Replace air switch.
	Gas pressure too low.	Check manifold pressure and adjust to pressure specified on rating plate. If this pressure cannot be obtained, have gas supplier check main pressure.
	Improper orifices.	Orifices have been sized for type of gas specified on rating plate. Check with gas supplier to determine specifications for gas being used. If different from rating plate, contact factory and obtain proper orifices.
	Electric power to heating unit turned off.	Turn power on.
	Line fuse or heater circuit fuse blown to unit.	Replace fuse.
	Defective relay.	Replace relay.
	Defective electric elements.	Replace elements.
	Defective thermostat.	Replace thermostat.
	Defective safety overload thermostat.	Replace thermostat.
	Lint compartment door open.	Close door.
Main burners burning improperly.	Orifice location incorrect	Space 1/4" (7 mm) from burner opening
	Dirt in burner.	Blow out.
	High gas pressure.	Adjust gas pressure per rating plate.
	Orifice too large.	Send to factory for correct orifices.
	Restricted or blocked exhaust.	Clean exhaust.
Main burner cycles on and off.	Direct spark ignition defective.	Replace direct spark igniter.
Low or high gas flame.	Incorrect main burner orifices.	Replace orifices. Check factory for correct size.

Troubleshooting Chart

Troubleshooting Chart

TROUBLE	CAUSE	REMEDY
Dryer too hot.	Incorrect main burner orifices.	Replace orifices. Check factory for correct size.
	Inadequate make-up air.	Make-up air must be 4 to 6 times the exhaust area of the dryer.
	Lint accumulated.	Remove lint.
	Exhaust duct dampers.	Must be full open- replace if not.
	High gas pressure.	Adjust gas pressure per rating plate.
	Partially restricted or inadequately sized exhaust system.	Check service section for recommended sizes. Remove obstructions or lint build up from duct work. NEVER use smaller size exhaust duct. ALWAYS use larger size.
	Defective thermostat.	Replace thermostat.

Direct-Spark Ignition Operation

DIRECT SPARK IGNITION OPERATION

NOTE: Some models are equipped with a dual ignition system. The dual ignition system contains two direct spark ignition modules in parallel. Each module has its own flame sense circuit and acts independently of the other. If either bonnet limit thermostat opens because of high heat or flame impingement, the entire ignition system will shut down.

1. When a call for heat is received from the control supplying 24VAC to the ignition control module, the pre-purge delay timer begins. This delay time allows any air/sediment to be ejected prior to burner ignition. Following the pre-purge delay period, the gas valve is energized and the spark ignitor sparks for the trial ignition period.
2. When a flame is detected during the trial for ignition period, the spark ignitor shuts off and the gas valve remains energized.
3. If no flame is detected by the flame sense circuit, the ignition control module will go into safety lockout. The valve will be turned off immediately. If the module has multiple retries and no flame is detected, the gas valve is de-energized and the module goes into an interpurge delay. After this delay, the module will attempt another trial for the ignition period. This will continue until the number of retries has been used up. At the time, the module will go into safety lockout.
4. Recovery from safety lockout requires one of the following:
 - a. A manual reset by opening and closing the loading door.
 - b. After one hour if the control thermostat is still calling for heat, the module will automatically reset and the trial for ignition period will start over.
5. Opening the loading door will cause the flame to extinguish. Closing the door and starting the dryer will restart the trial for ignition period.
6. Once the control thermostat has been satisfied and/or the drying timer has been timed out, the ignition control module(s) will be de-energized, the gas valve(s) will be de-energized and the flames will extinguish.
7. The machine will continue to run in a cooldown mode without heat. This process will cool the load to the touch and help to eliminate wrinkling.

**DIRECT SPARK
IGNITION OPERATION
FLOW CHART**

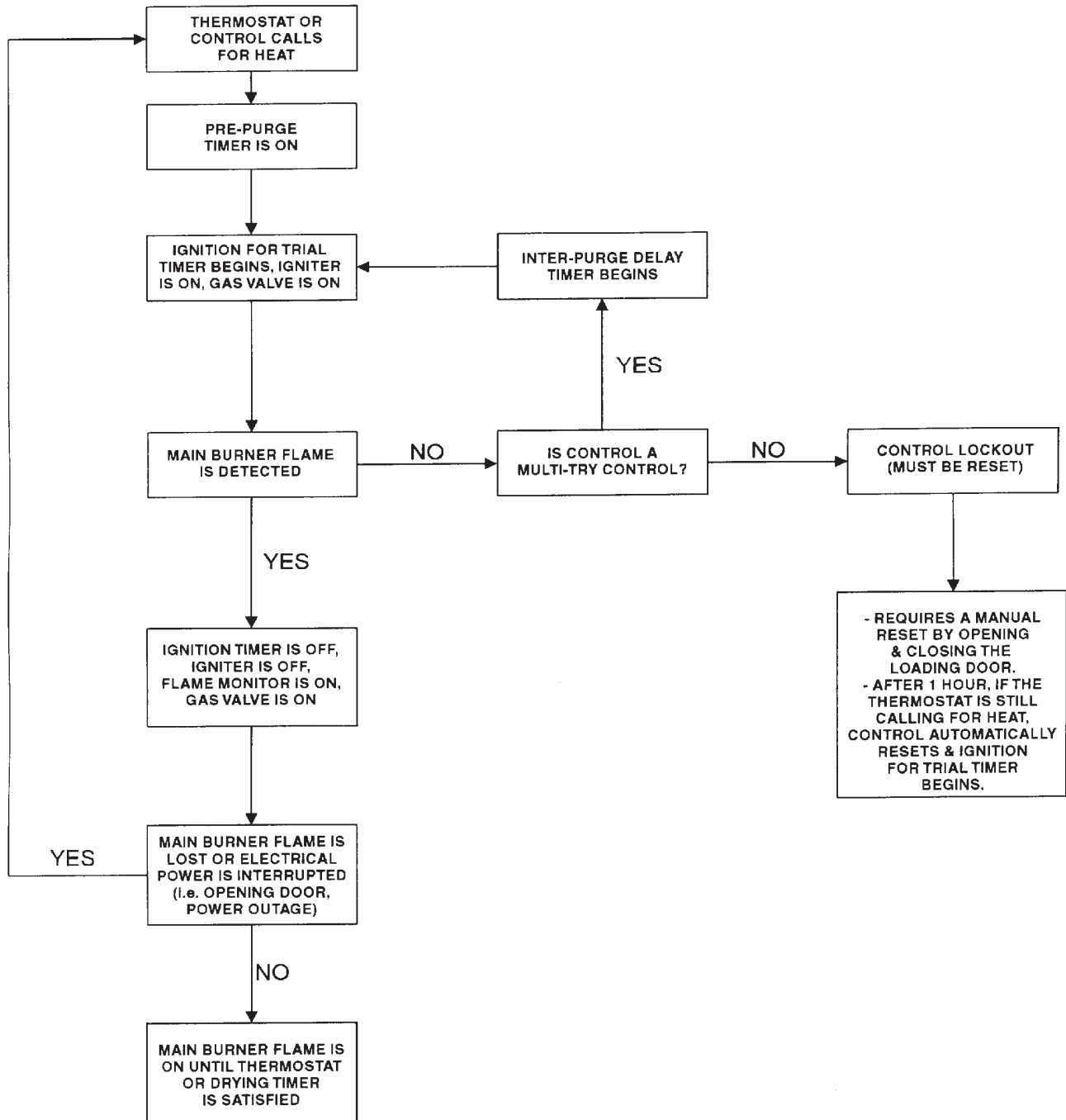

General Maintenance

GENERAL MAINTENANCE

1. **Clean lint trap daily.** Remove lint before or after each day of operation. A clean lint trap will increase the efficiency of the dryer and the moisture-laden air will be exhausted outside more quickly.
2. **Keep basket and sweep sheets clean.** Clean as often as needed. The basket and sweep sheets are accessible by removing the front panel of the dryer.
3. **Gas burners.** Check and clean often.
4. **Pulleys and belts.** Keep clean as oil and dirt will shorten the life of a belt. Check periodically for alignment. Pulley shafts must be parallel and the grooves must be aligned. Check belt tension periodically. Adjust tension by movement of idler bracket. Lubricate idler pulley once every two months using six grams of high temperature grease. Do not over-grease.
5. **Electric motor.** Keep motor clean and dry. Motors are packed with sufficient grease for 10 years normal service. After that, bearings and housing should be cleaned and repacked one third full with Chevron grease No. SR1-2. See label on motor for further information.

If motor overheats, check voltage and wiring. Low voltage, inadequate wiring and loose connections are the main cause of motor failures.
6. **Adjustable leveling bolts.** One at each corner permits accurate alignment of dryer.
To adjust: Block one corner of dryer up off the floor, loosen hex nut. With wrench, turn bolt clockwise to raise dryer, opposite to lower. Rear bolts are outside of dryer and front bolts are inside lint trap compartment.
7. Periodically clean and examine exhaust system.
8. Keep dryer area clean and free of gasoline, combustible materials and other flammable liquids or vapors.
9. Do not obstruct the flow of combustion (make-up) air and ventilating air.
10. Check gas pressure periodically.
11. **Main Basket Bearings.** Lubricate once every six months using six grams of high temperature grease. Do not over-grease.

Bearings Replacement Instructions (Illustration)

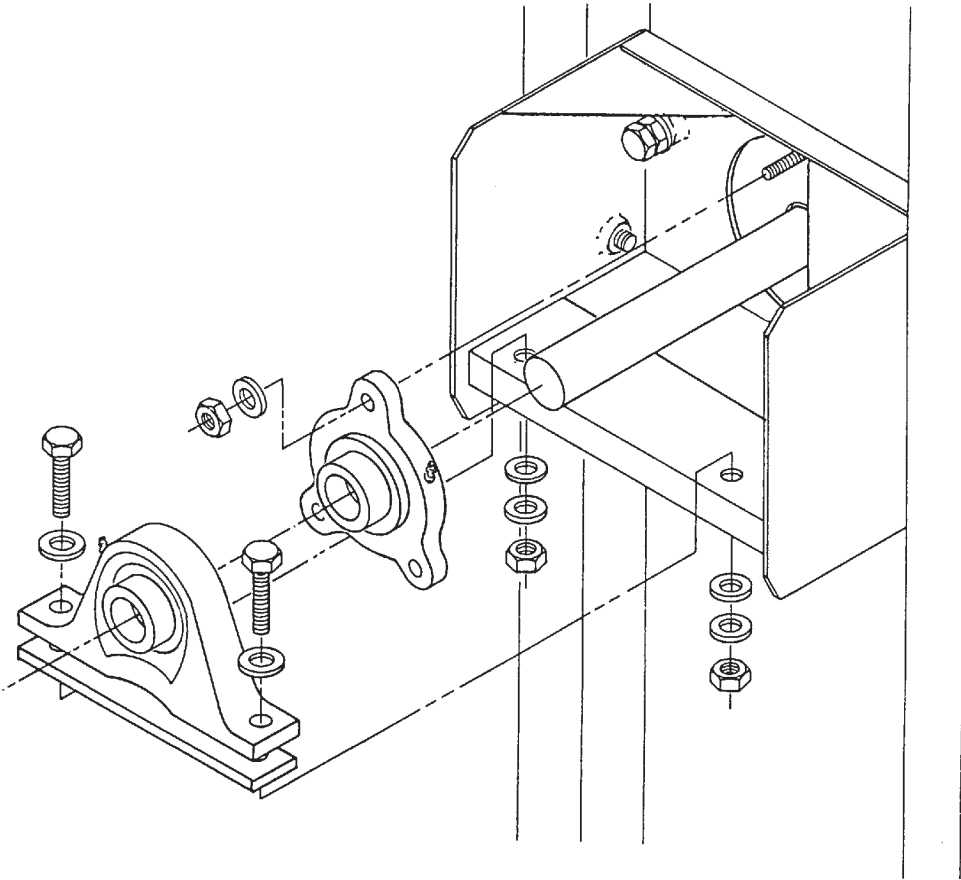

BEARING REPLACEMENT INSTRUCTIONS

- Step 1** Remove belt guard, V-belt, spacer and basket sheave.
- Step 2** Loosen set screws on the flange bearing and on the pillow block bearing.
- Step 3** Remove the bolts holding the pillow block bearing and take it off the shaft.
- Step 4** Remove the nuts and washers holding the flange basket bearing and take it off the dryer.
- Step 5** Inspect the bearings for damage and replace as necessary, in reverse order of removing them. Before tightening securely, align basket per instructions on separate instruction sheet.
- Step 6** Lubrication guide---Bearings never need lubrication. They have been permanently lubricated by the supplier with a high temperature grease.

Basket Alignment Instructions

FIG. 1

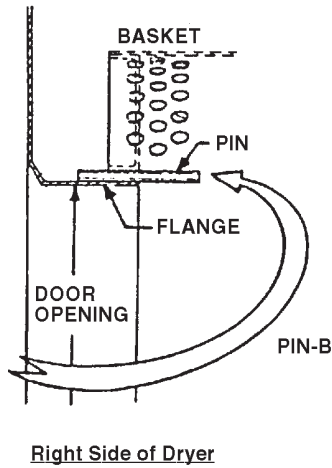

FIG. 2

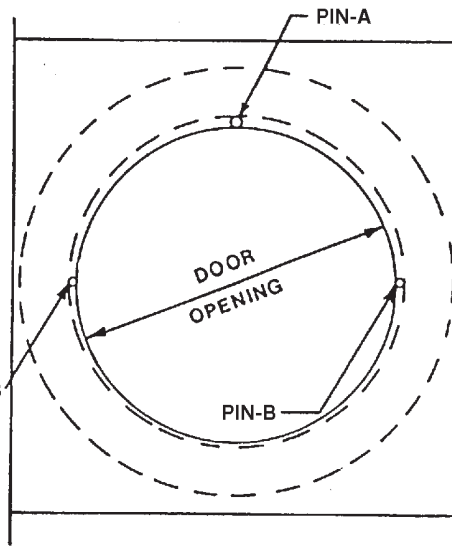
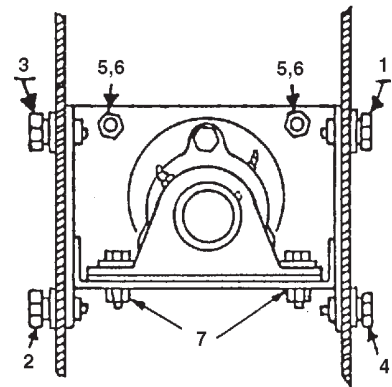

FIG. 3



Front of Dryer
 PIN-A - 1/2 (13 mm) DIA.
 PIN-B - 5/16 (8 mm) DIA.

BASKET ALIGNMENT INSTRUCTIONS

- Step 1** Loosen both eccentric locking collars on the two basket bearings (flange and pillow block types). Loosen the set screws and turn clockwise. If necessary, use a punch and mallet, striking the punch hole in a clockwise direction to break it loose.
- Step 2** Loosen the four side bolts, "1, 2, 3, 4" on the basket bearing bracket (see FIGURE 3). Loosen the two adjusting bolts and locknuts "5, 6" inside the bracket. And loosen the bolts "7" on the pillow block bearing.
- Step 3** Place one "A" and two "B" diameter pins inside the drying compartment between the rim of the basket opening and the rim of the door opening in the positions shown in FIGURES 1&2. Check the two "B" pins for equal clearance.
NOTE: Push the basket toward the rear.
- Step 4** With the pins in position, lock the collar nearest the rear wall of the dryer on the shaft by striking the punch hole in a counterclockwise direction. Tighten the set screw.
- Step 5** Tighten the side bolts "1, 2, 3, 4" in numerical order. Tighten the bolts "7" on the pillow block bearing. And tighten the bolts "5" and locknuts "6".
- Step 6** Remove the aligning pins and if alignment is okay, then tighten the collar on the pillow block bearing the same as in *Step 4*.

CAUTION

CAUTION
 Check to see that the set screws are wrench tight on the locking collars.

Basket Shimming Instructions

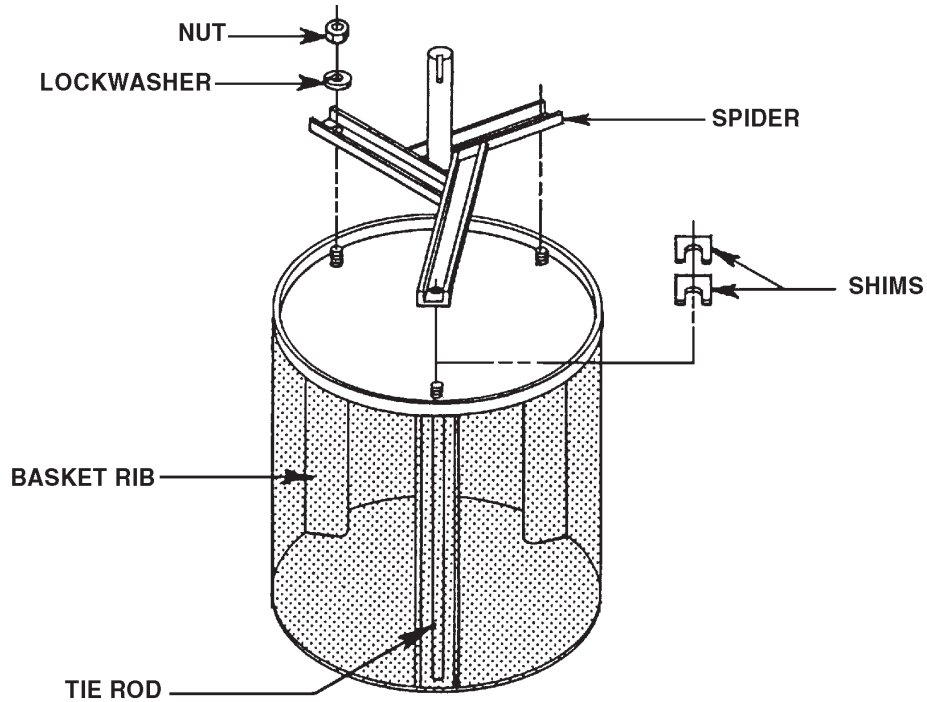

BASKET SHIMMING INSTRUCTIONS

This procedure is normally necessary when replacing either the basket or the spider assembly on any dryer. Proper shimming is crucial to obtain a true running basket.

- A. Align the basket as per instructions in the manual.
- B. Rotate the basket to determine where the most out-of-round point is (where the basket scrapes or comes closest to scraping the sweep sheet).
- C. Mark this position and the nearest rib to this position.
- D. Remove the basket (do not loosen the alignment bolts).
- E. With the basket on the floor (spider up), place one or two shims between the spider leg and the back of the basket at the marked rib position. (See drawing.)
- F. Re-insert spider and basket assembly and re-check cylinder.
- G. If at this point, basket is still out-of-round, procedure must be repeated starting with *Step "B"*.
- H. Upon completion of shimming process, realignment of basket is necessary.

NOTE

If the point mentioned in *Step "B"* is between two ribs, both ribs might have to be shimmed.

Air Switch Adjustment (Illustration)

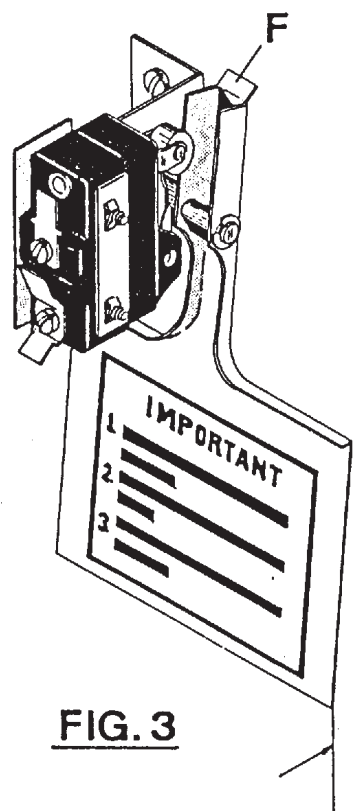

FIG. 3

$\frac{3}{4}$ " (20mm)

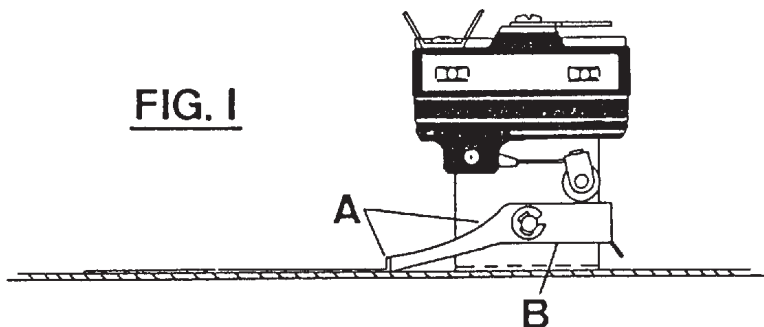

FIG. 1

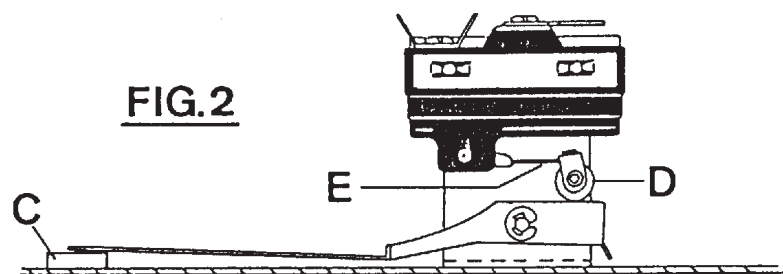
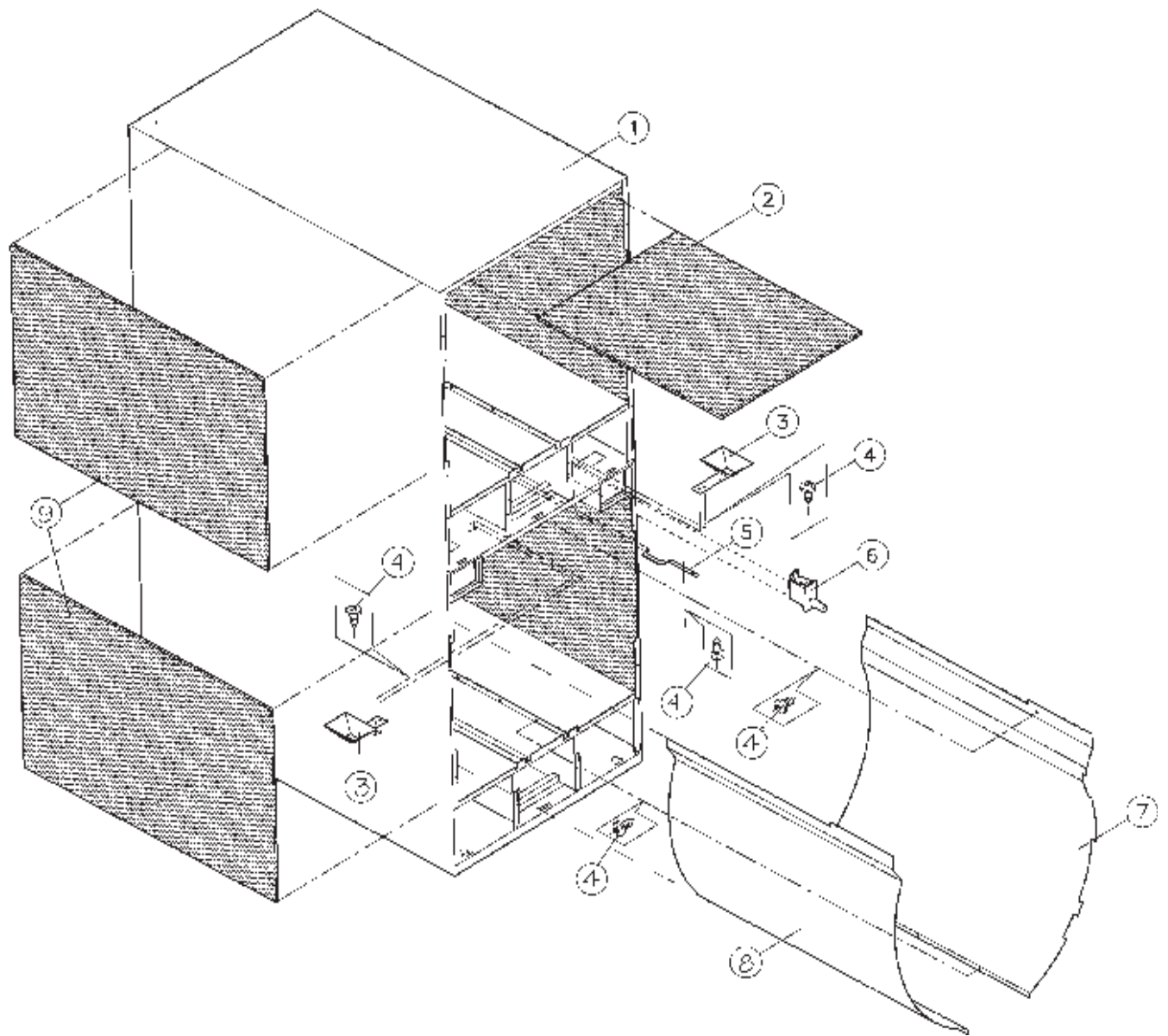

FIG. 2

AIR SWITCH ADJUSTMENT

1. Shut off current; disconnect leads and remove air switch.
2. Lay air switch assembly on flat surface. Adjust air blade at "A" (FIGURE 1) so that air blade lays flat and surface "B" is parallel to the flat surface.
3. Place $\frac{3}{8}$ " (10 mm) x $\frac{5}{8}$ " (16 mm) spacer bar or equivalent "C" (FIGURE 2) under air blade in position shown; hold switch mounting bracket firmly and adjust switch actuator "D" with needle nose pliers at "E" by twisting actuator right or left whichever is needed so that switch closes when end of air blade engages bar "C".
4. Maximum opening of air switch must be no greater than $\frac{3}{4}$ " (20 mm) (FIGURE 3). Bend tab "F" in or out to maintain this dimension.
5. Re-install air switch assembly on rear of dryer.
6. Re-check operation of air blade. Switch must close before air blade engages face of opening and re-open before stop "F" engages.



Ref. No.	Part No.	Description
1	TUD0083	JACKET WELDED ASS'Y
2	TUD0283	INSULATION, TOP
3	TUD0375	COIN CHUTE
4	TU7733	SCREW SELF TAP
5	TUD0258	SPRING RETAINER
6	EA-00650-0	SWITCH, LINT DRAWER
7	TUD0241	SWEEP SHEET LR
	TUD0239	SWEEP SHEET UR
8	TUD0240	SWEEP SHEET LL
	TUD0134	SWEEP SHEET UL
9	TUD0282	INSULATION SIDE

DOOR ASSEMBLY

Parts—Tumbler Assembly

TUD0387 - LOWER FRONT PANEL AND DOOR ASSY with Painted Steel Door
TUD0272 - UPPER FRONT PANEL AND DOOR ASSY with Black Steel Door
TUD0273 - LOWER FRONT PANEL AND DOOR ASSY with Black Steel Door

COIN METER MODELS

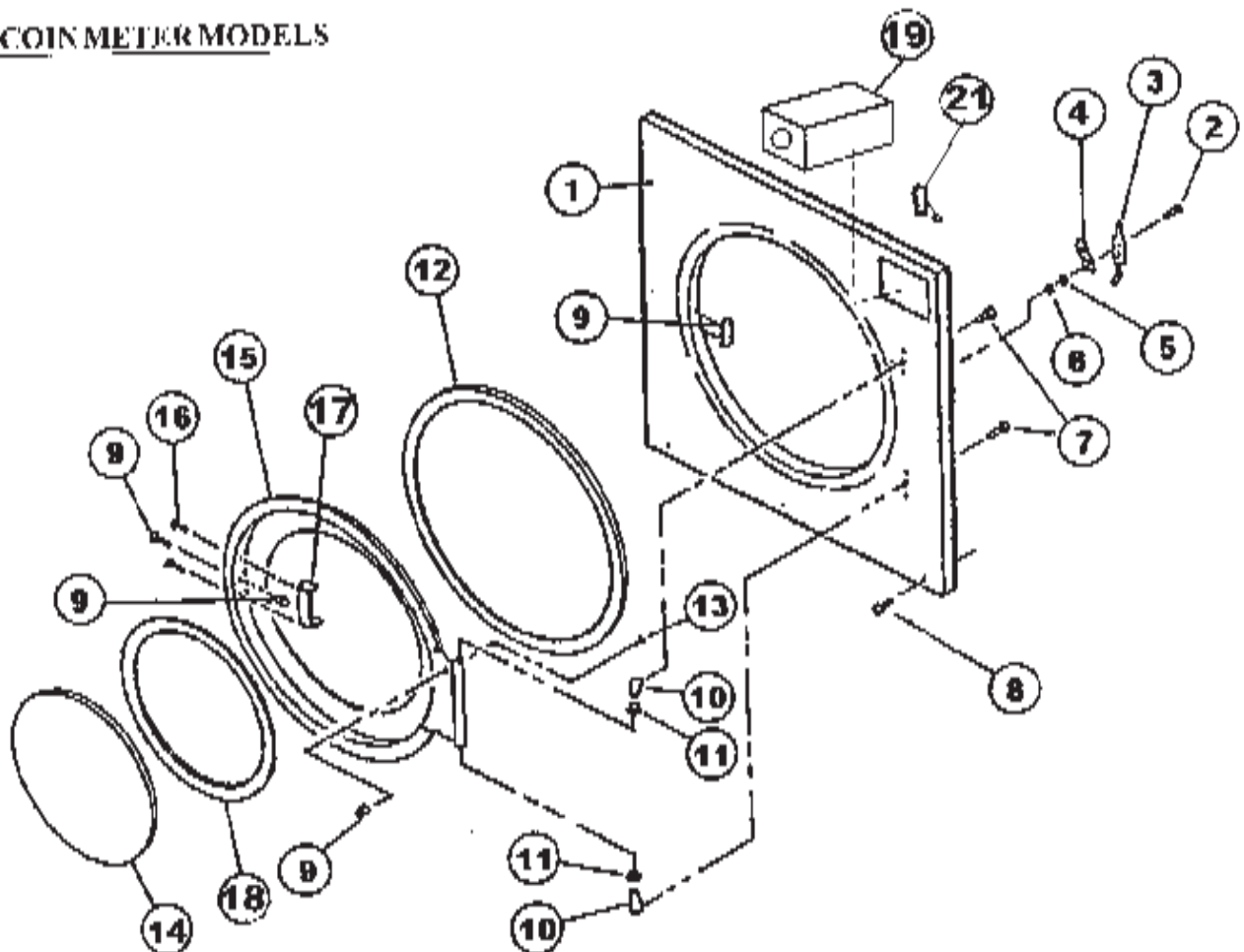

1	TU0307	Upper Front Panel w/Door Catch (Specify Color)	11	PIF177	Delrin Bearing (Pkg. 1)
	TUD0308	Lower Front Panel w/Door Catch (Specify Color)	12	TU2090	Basket Door Seal
2	M262	#8-32 x 1/8" Truss Head Screw	13	TU4899	#10-32 x 3/8" Machine Screw
3	TU0069	Door Switch Actuator	14	TU7862	Door Glass (Plain)
4	TU2105	Door Switch Spring	15	TU17171	Basket Door (Specify Color)
5	FB187	#8 Split Lockwasher	16	TU3215	#10-32 x 3/8" Taptic Screw
6	TU3266	#8-32 Hex Nut	17	TU7874	Basket Door Handle
7	TU2836	5/16" 18 x 1/2" Hex Head Screw	18	TU7169	Rubber Gasket
8	TU2878	#10 x 3/8" Sheet Metal Screw	19	TU9225	Coin Vault (Not Part of Assembly)
9	TU5158	Door Catch Assembly	20	CA 00675-1	Insulation (Not Shown)
10	TU2236	Hinge Post	21	TU3445	Switch, Door
			22	SB 00954-0	Clip - Finerman (Not Shown)
			23	SB-00955-0	Screw #4 x 3 1/4 Philips (Not Shown)

NOTE: TUD0370-Actuator Door Switch Assembly Consists of Ref. No. 2-6 and 21-23
 TU9040-Door Assembly Consists of Ref. No 11-18 (Specify Color)

CONTROL PANEL

PARTS - TUMBLER ASSEMBLY

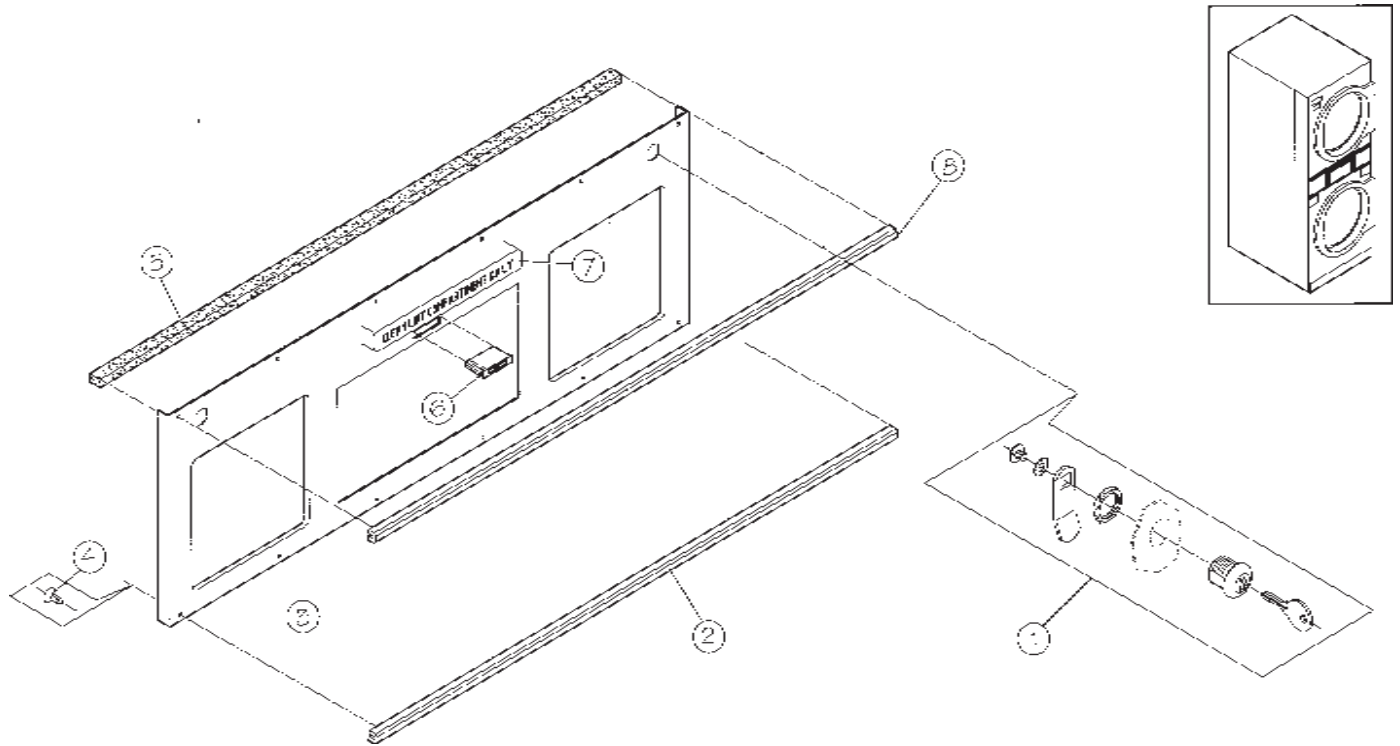

Ref. No.	Part No.	Description
1	LA-00121-0	LOCK AND KEY CONTROL
2	CA-00748-0	TRIM, BOTTOM ALM
3	TUD0234WH	COVER PLT W/A
4	SB-00951-0	SCREW #8
5	TU2853	LINT DRAWER GASKET
6	TUD00366	MAGNET SNAP CATCH
7	TU7858	LABEL, INSTRUCTIONS
8	CA-00749-0	TOP TRIM, ALM

LINT DRAWER ASS'Y

PARTS - TUMBLER ASSEMBLY

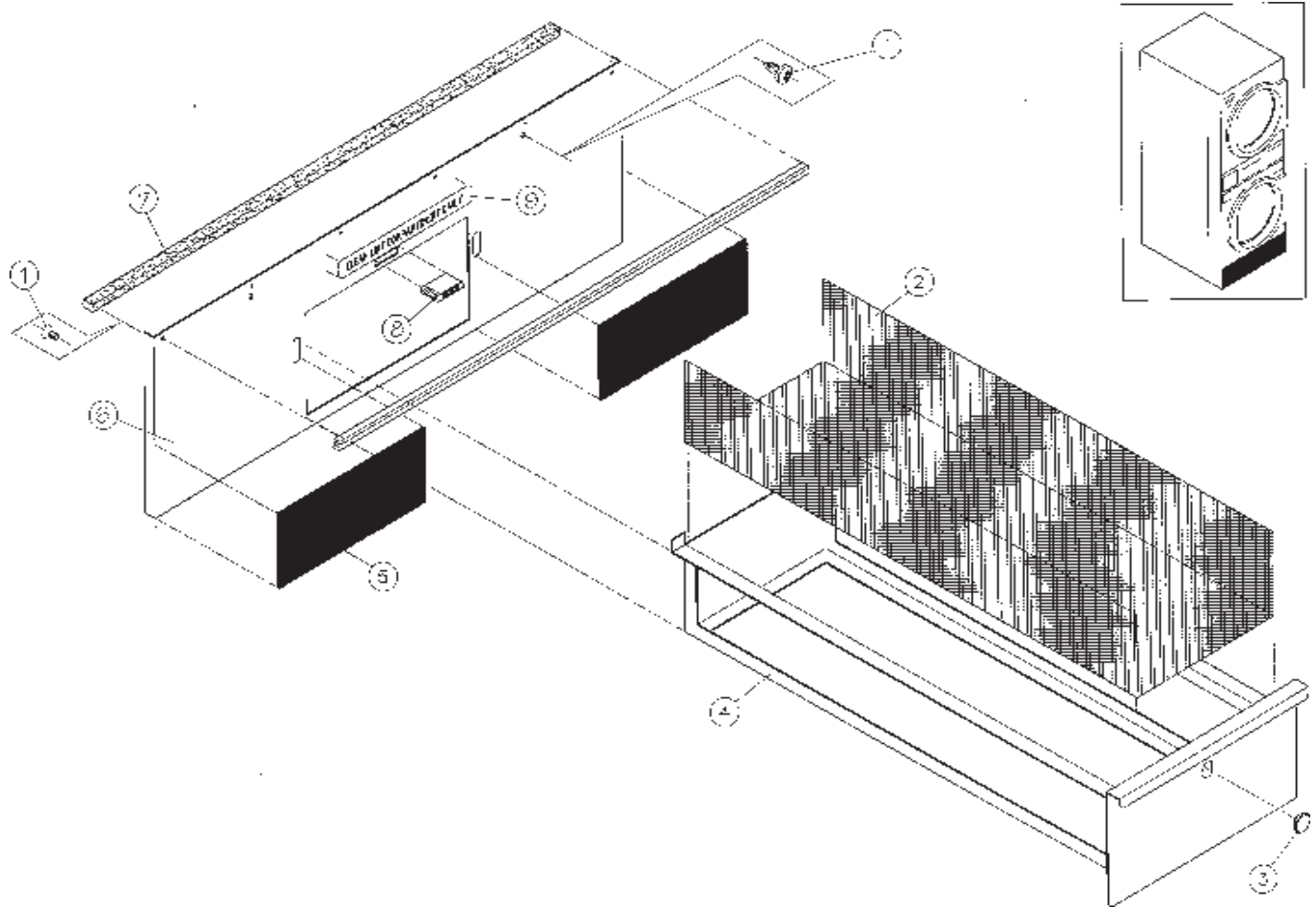

Ref. No.	Part No.	Description
1	SB-00951-00	SCREW, #8
2	TUD0256	MESH SCREEN
3	TUD0412	PLUG-DOUBLE-D(NO LOCK)
3A	LA-00121-0	LOCK
4	TUD0279WH	FRAME, DRAWER(NO LOCK)
4A	TUD00048WH	FRAME, DRAWER(LOCKING)
5	TUD0198	KICK PLATE
6	TUD0249WH	COVER PLT W/A
7	TU2853	GASKET
8	TUD00366	MAGNET SNAPCATCH
9	TU7858	LABEL, INSTRUCTIONS

THERMOSTAT ASS'Y

PARTS - TUMBLER ASSEMBLY

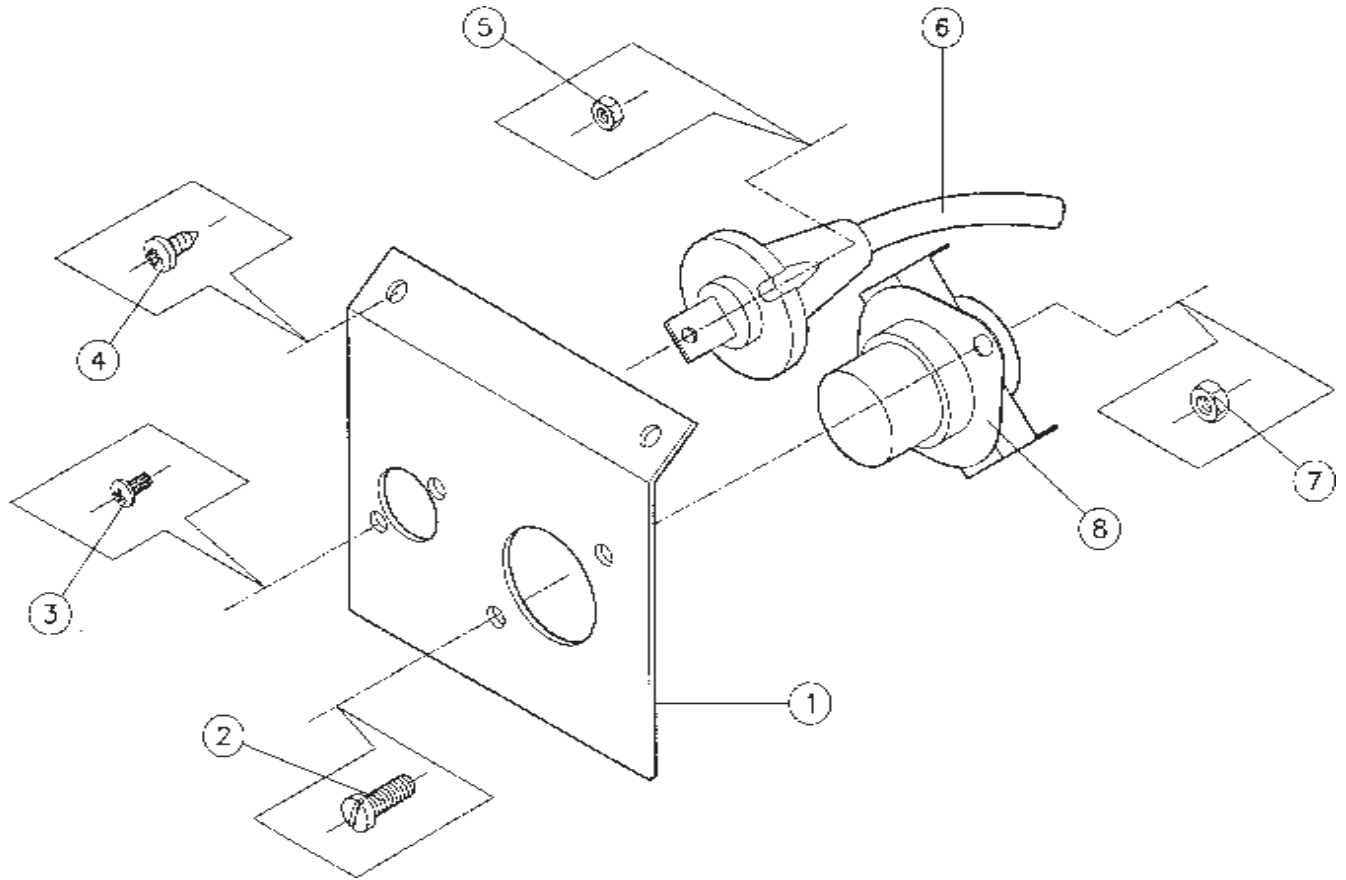

Ref. No.	Part No.	Description
1	TUD0259	THERMOSTAT BRACKET
2	TU7733	SELF TAP SCREW
3	SB-00952-0	SCREW 6/32-3/8
4	TU7733	SELF TAP SCREW
5	TU3400	NUT, HEX #6-32
6	TU11991	THERMOSTAT-CONTROL
7	TU3266	NUT, BRASS-HEX #8-32
8	EA-00594-0	SAFETY THERMOSTAT

CONTROL-COIN

PARTS - TUMBLER ASSEMBLY

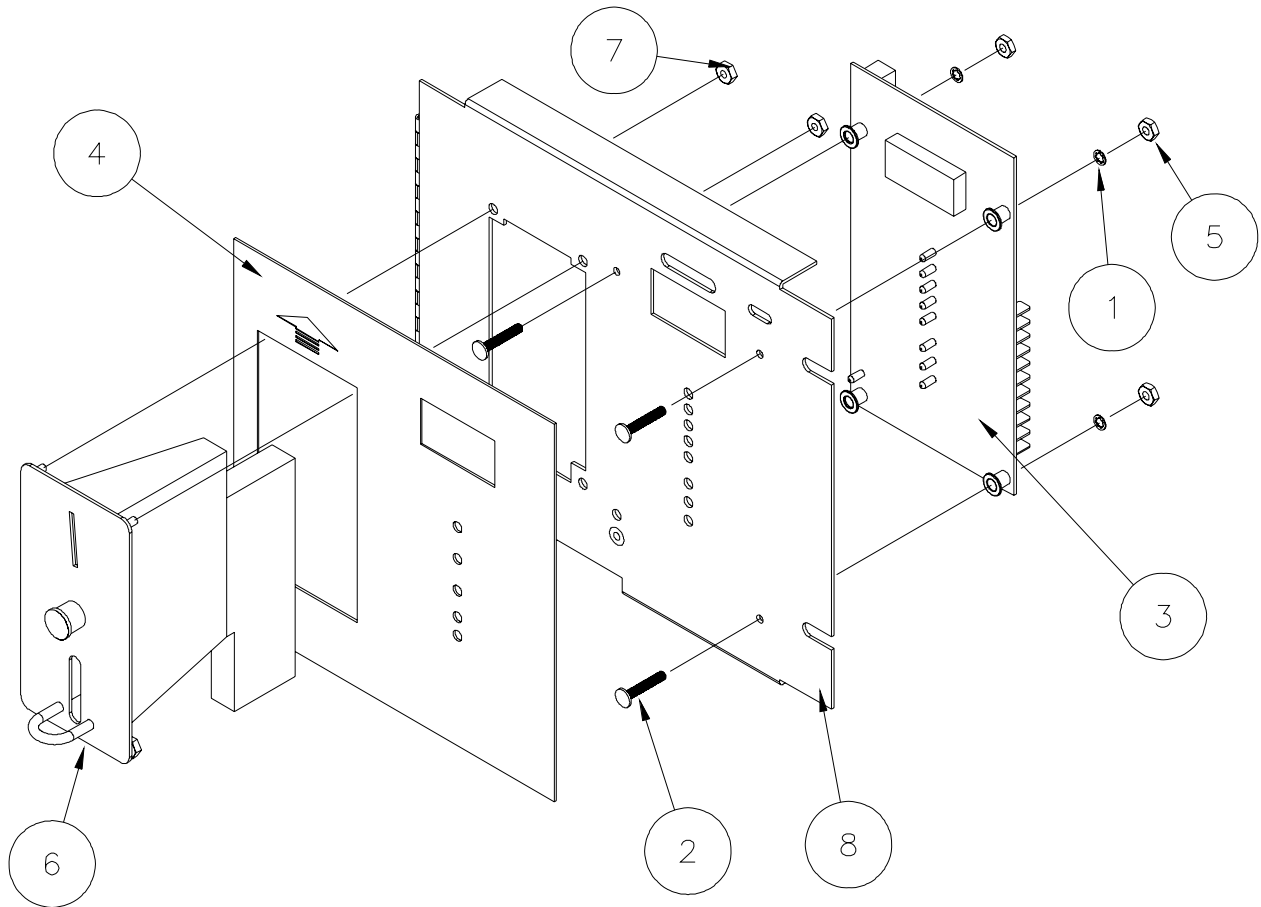

Ref. No.	Part No.	Description
1	M270	#6 LOCK WASHER
2	TU12253	STUD, #6-32
3	TU14404	CONTROL (DMP)
4	TU14451	OVERLAY (UPPER)
	TU14406	OVERLAY (LOWER)
5	TU3400	NUT, #6-32
6	TUD0336	COIN DROP
7	TUD0367	#5-40 NUT
8	TUD0452	ASM, DMPC PANEL (UPPER)
	TUD0453	ASM, DMPC PANEL (LOWER)

PARTS - TUMBLER ASSEMBLY

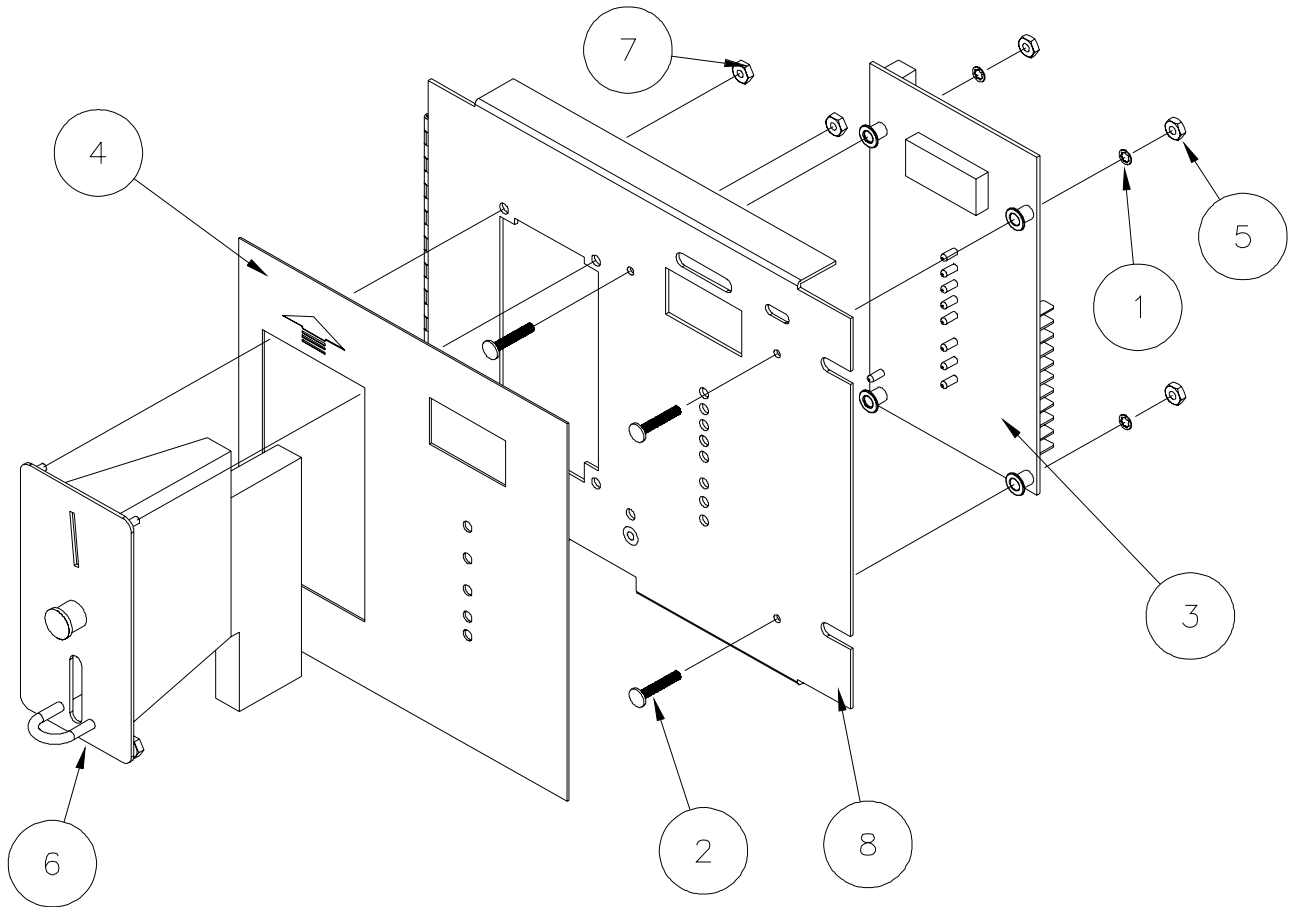

Ref. No.	Part No.	Description
1	M270	#6 LOCK WASHER
2	TU12253	STUD #6-32
3	TU14404	DMP CONTROL
4	TU14405	OVERLAY
5	TU3400	NUT, #6-32
6	TUD0458	LFT DMP PANEL (UPPER)
	TUD0459	RHT DMP PANEL (LOWER)

BASKET ASS'Y

PARTS - TUMBLER ASSEMBLY

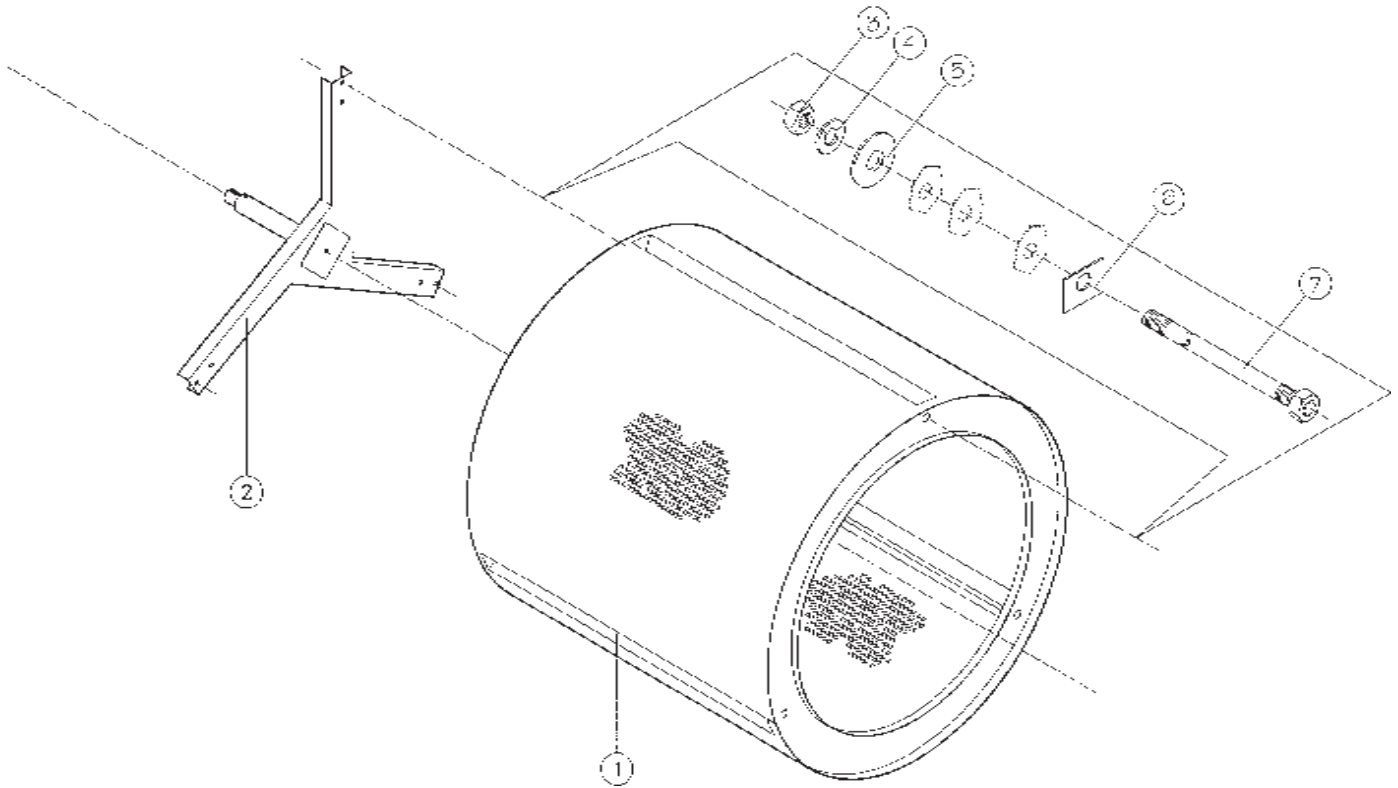

Ref. No.	Part No.	Description
1	TU2083	BASKET ASS'Y
2	TUD0089	SPIDER W/A
3	TU2882	NUT HEX 1/2-20
4	TU2883	WASHER 1/2"-CUT
5	TU2831	1/2" WASHER
6	TU5863	ADJUSTING SHIM
7	TU2313	BOLT 1/2-20 x 31

PARTS - TUMBLER ASSEMBLY

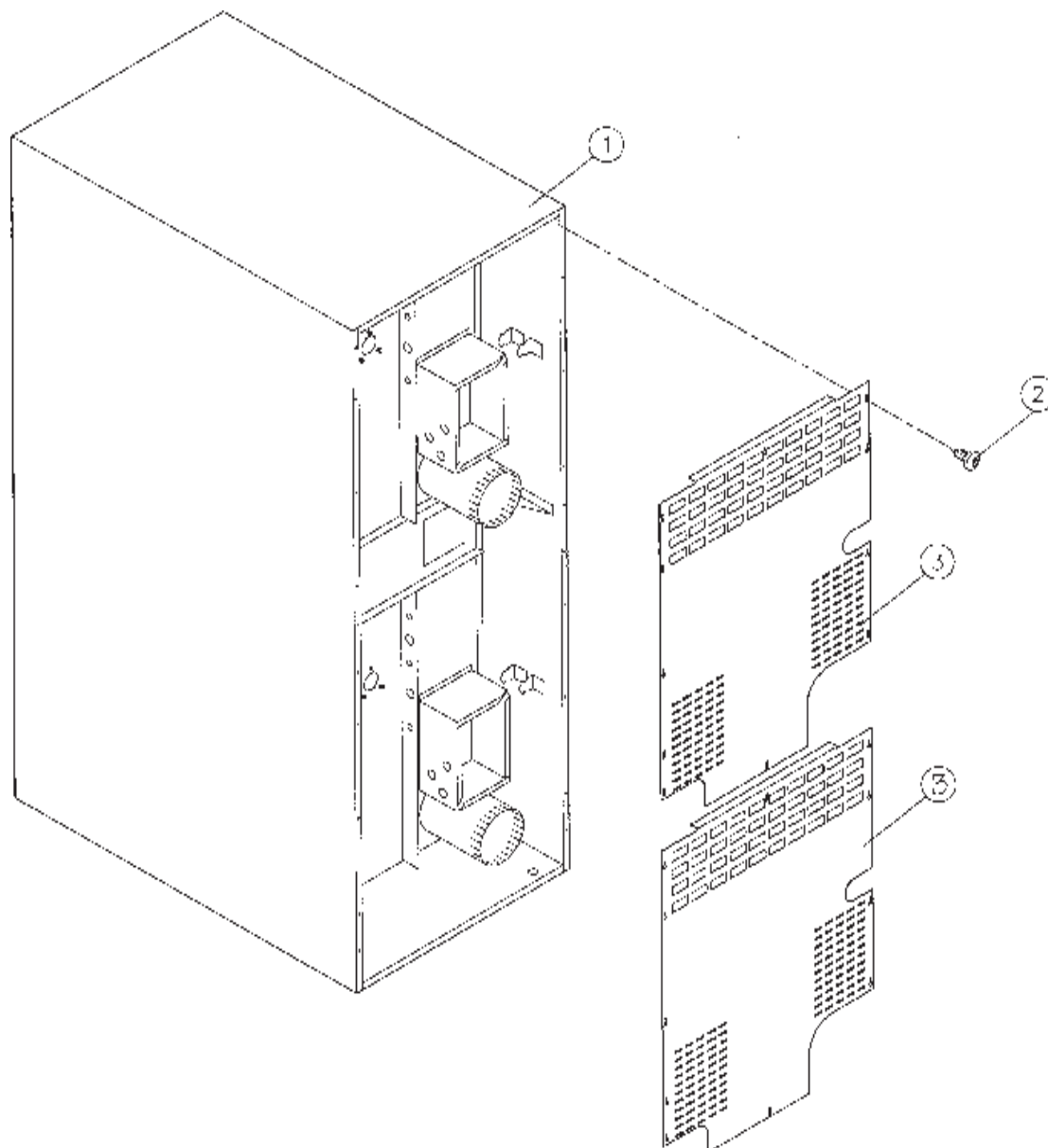

Ref. No.	Part No.	Description
1	TUD0083	JACKET WELDED ASS'Y
2	TU7733	SCREW SELF TAP
3	TUD0246	BELT GUARD COVER

POWER TAP

PARTS - TUMBLER ASSEMBLY

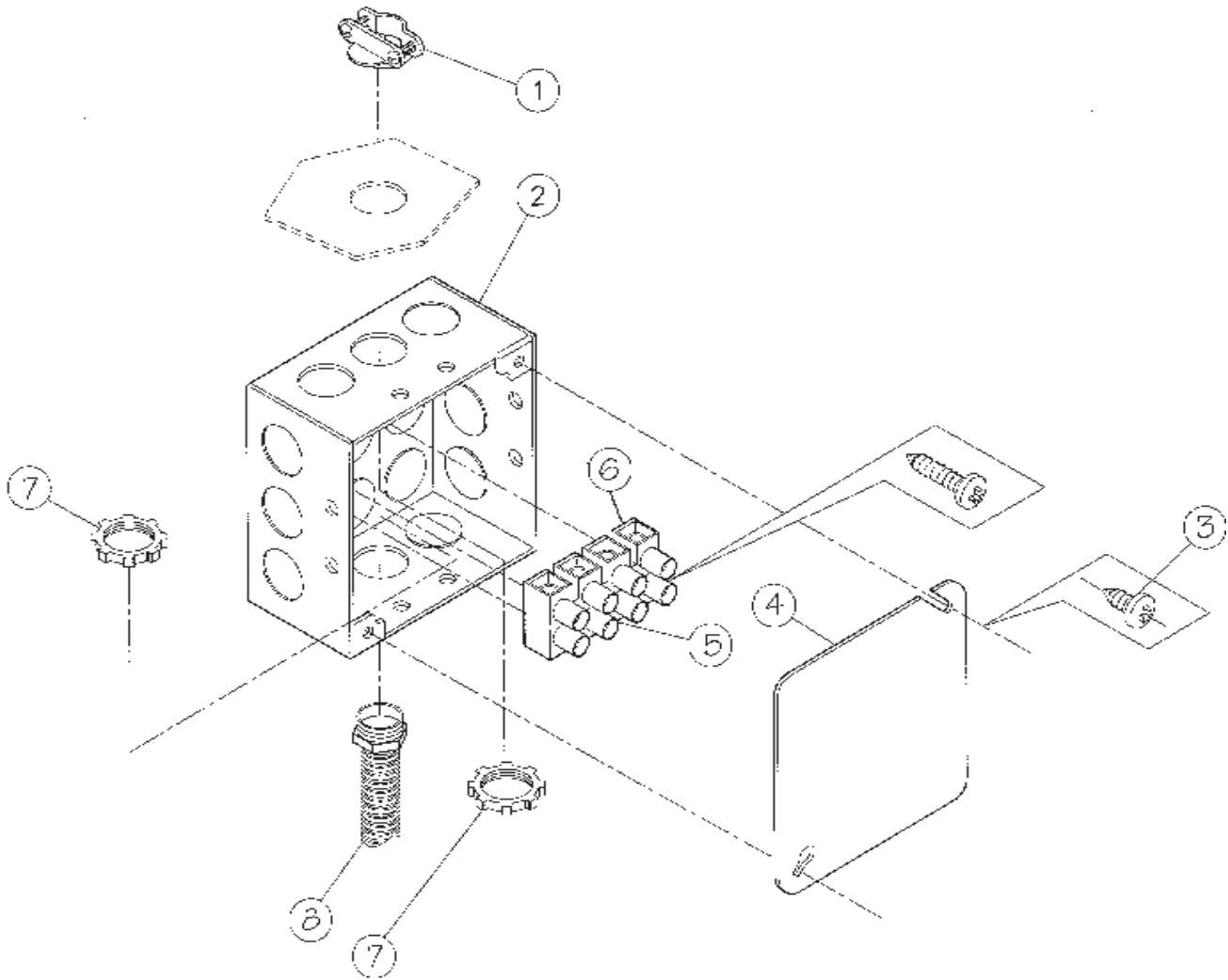

Ref. No.	Part No.	Description
1	C1365	REGAL CONNECTOR
2	SC517	J-BOX
3	TU7733	SELF TAP SCREW
4	SC518	J-BOX COVER
5	TU14958	TERMINAL BLOCK
6	TU14959	TERM. BLK END/GRND
7	C170	BUSHING
8	CFA2400	FLEXABLE CONDUIT

BASKET SUPPORT

PARTS - TUMBLER ASSEMBLY

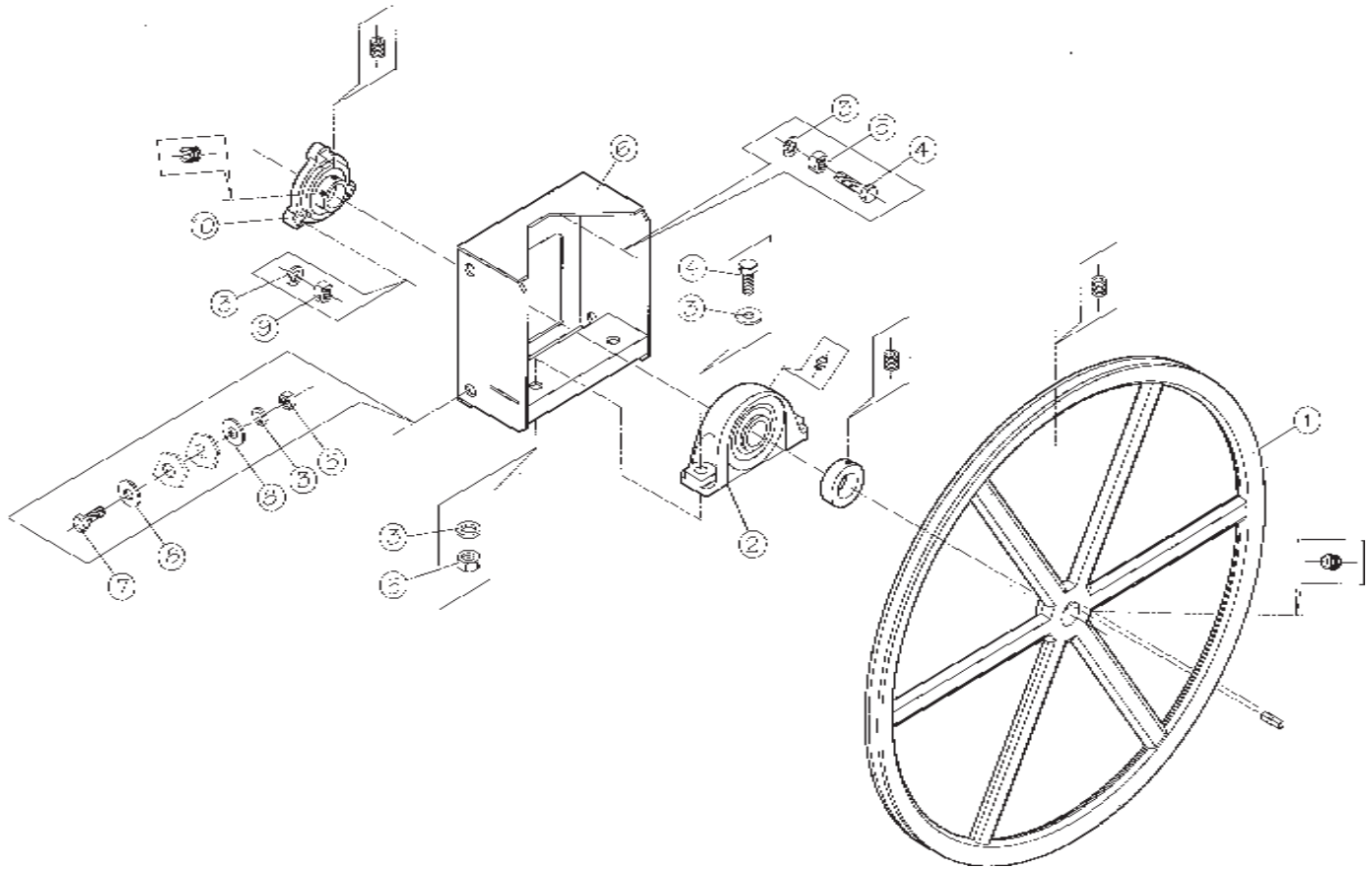

Ref. No.	Part No.	Description
1	TUD0076	PULLEY 18" CAST IRON
2	TU10676	BEARING, PILLOW BLOCK
3	OP251	WASHER, 1/2" FLAT
4	TU2195	1/2" BOLT
5	OP233	NUT, 1/2"
6	TUD0411	BEARING BOX ASSY
7	RC347	CAP SCREW 1/2-13
8	TU2883	WASHER 1/2" FLAT
9	TU13372	NUT, 1/2-13 W/NYLON
10	TU10002	FLANGE BEARING

MOTOR ASS'Y

PARTS - TUMBLER ASSEMBLY

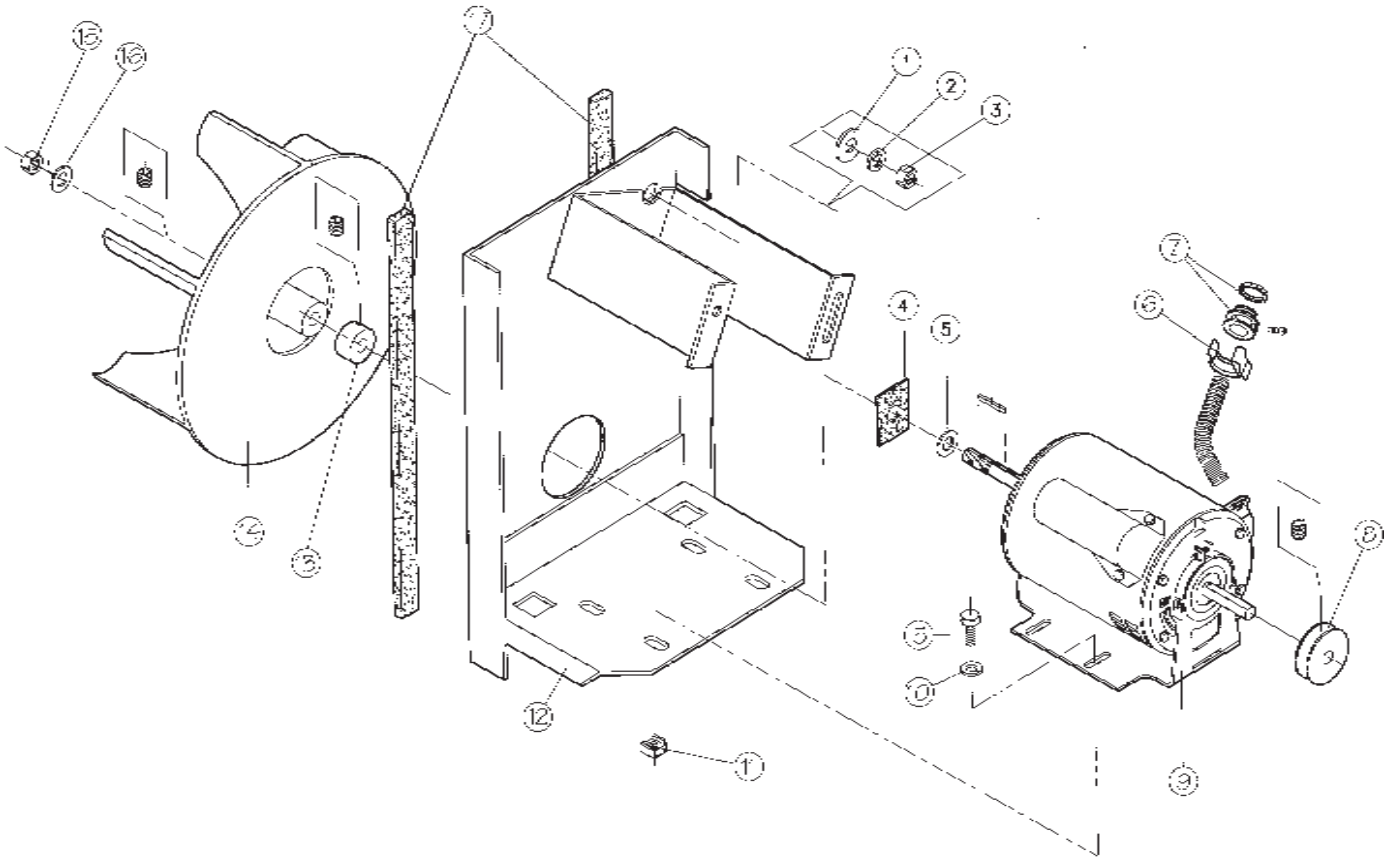

Ref. No.	Part No.	Description
1	IB140	3/8" FLAT WASHER
2	VSB134	3/8" LOCK WASHER
3	TU4787	NUT, 3/8-16
4	DA-00460-0	FELT SEAL
5	FB124	WASHER 5/16-18
6	EA-00648-0	BRACKET CLIP
7	EA-00211-0	CONNECTOR 3/8" STRT
8	DA-00510-0	PULLEY, 2.5 (50HZ)
	DA-00516-0	PULLEY, 2 (60HZ)
9	DA-00428-0	MOTOR 1/2HP-115/230V 1PH
	DA-00447-0	MOTOR 1/2HP-220/380V 1PH
10	VSB130	5/16 WASHER
11	C249	NUT
12	TUD0180	MOTOR MOUNT W/A
13	FG364	FAN SPACER
14	TUD0032	FAN
15	SB-00813-0	LOCK NUT
16	SB-00847-0	WASHER 1"
17	TU2853	FOAM GASKET

AIR SWITCH ASS'Y

PARTS - TUMBLER ASSEMBLY

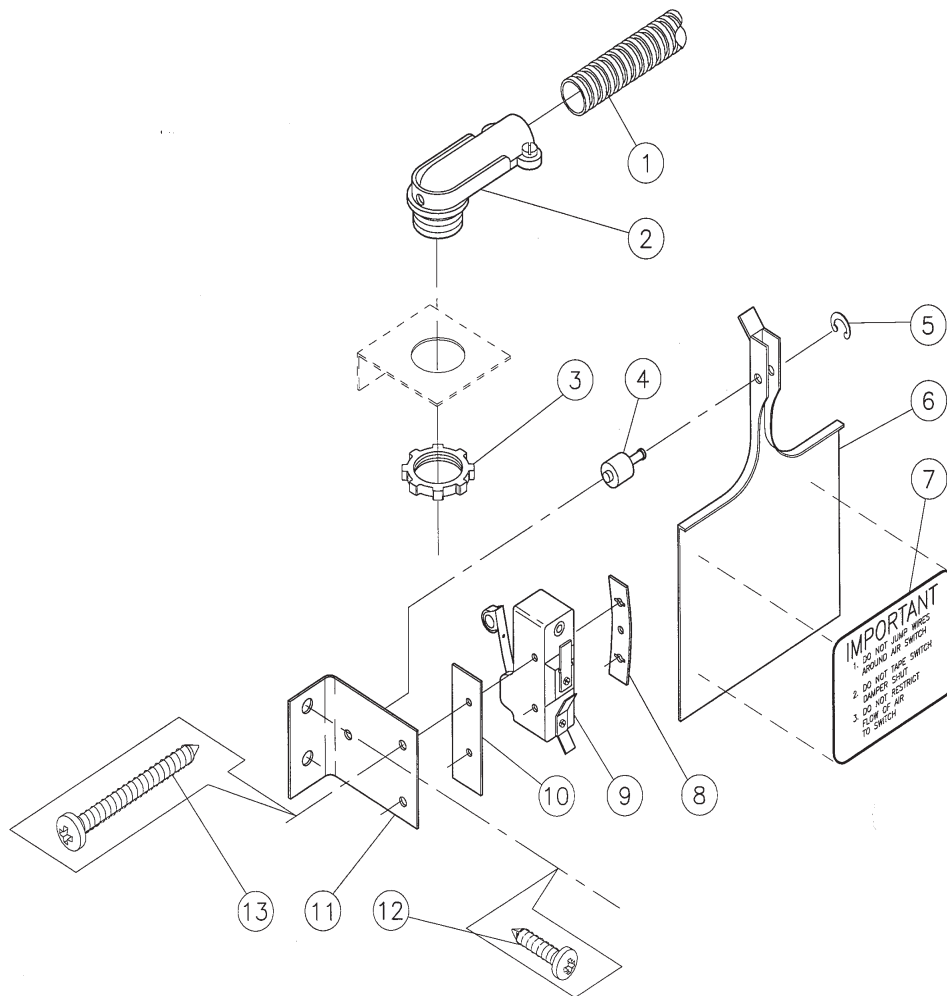

Ref. No.	Part No.	Description
1	CFA4000	CONDUIT 3/8"
2	F876	CONNECTOR, TOMIC ANGLE
3	C170	BUSHING
4	F888	"E" RING
5	TU2463	ACTUATOR ARM
6	TU3476	AIR SWITCH DECAL
7	TU1771	TINNERMAN NUT #6
8	TU8155	SWITCH
9	TU1770	INSULATOR
10	TU7733	SCREW SELF TAP
11	TU8171	AIR SWITCH BRACKET
12	TU3219	SCREW #6 RD HD

IDLER ASS'Y

PARTS - TUMBLER ASSEMBLY

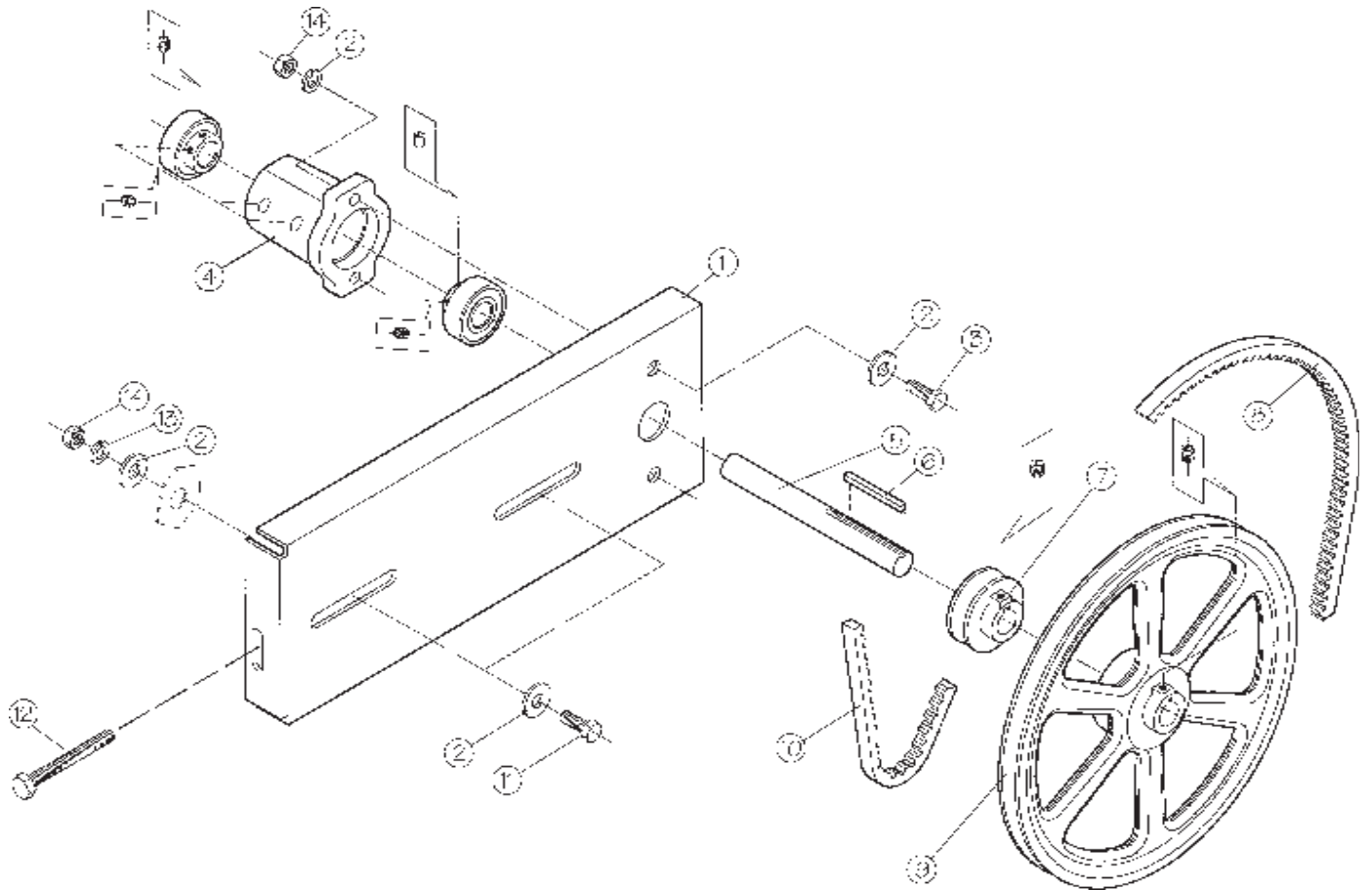

Ref. No.	Part No.	Description
1	TUD0174	IDLER ADJUSTING PLATE
2	VSB130	5/16" WASHER
3	FB124	5/16 BOLT
4	TUD0171	BEARING HOUSING ASS'Y
5	DA-11711-0	SHAFT
6	TUD0187	KEY
7	DA-00530-0	PULLEY 2.5"
8	TUD0196	AX34 BELT - COG
9	DA-00531-0	9" PULLEY
10	DA-00522-0	AX62 BELT - COG
11	TU5439	BOLT 5/16-8
12	PT539	1/4-20 CAP SCREW
13	TU3212	WASHER 5/16" TOOTH
14	C249	NUT 5/16"

REAR CONTROL BOX

PARTS - TUMBLER ASSEMBLY

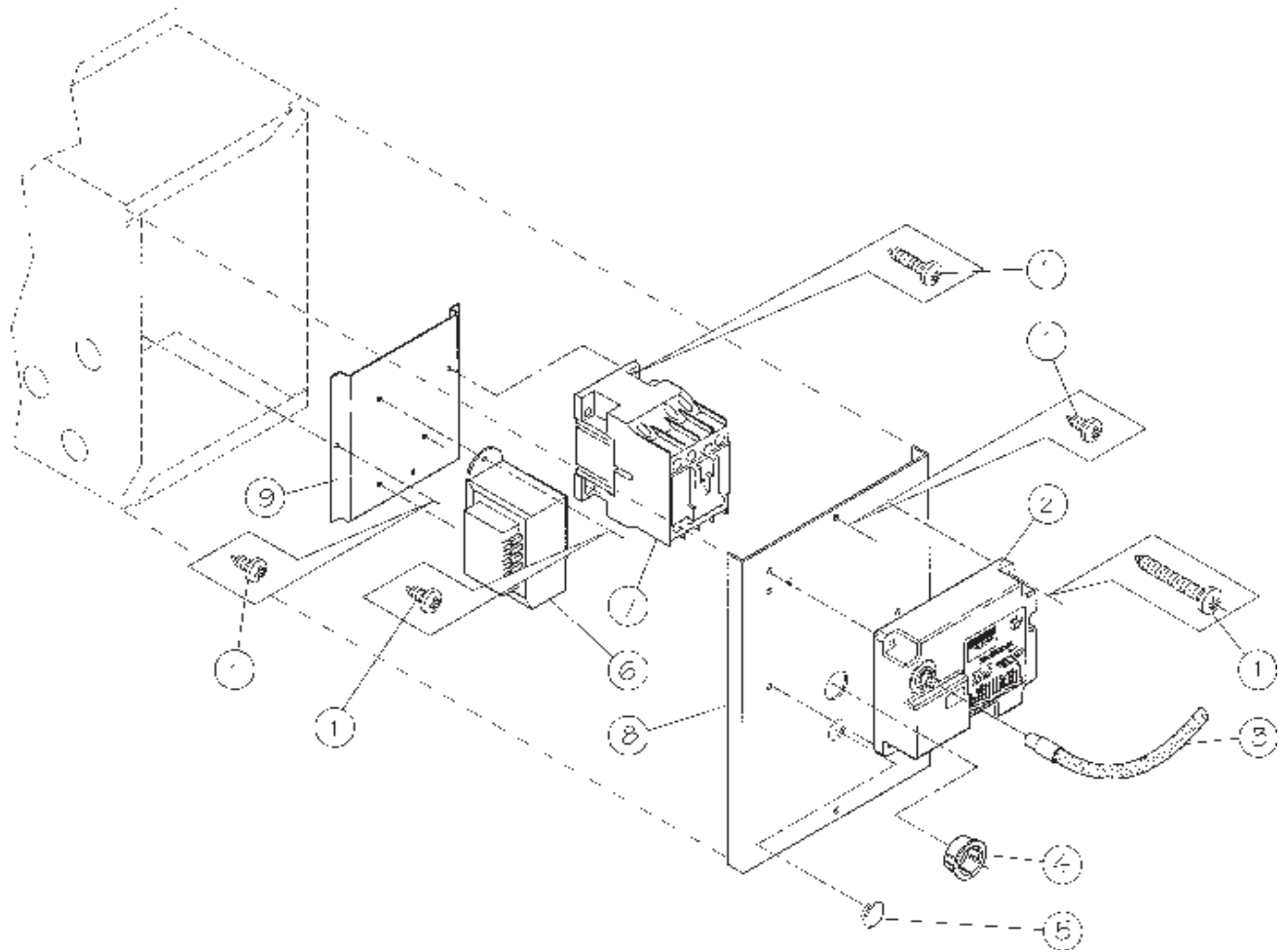

Ref. No.	Part No.	Description
1	TU7733	SCREW SELF TAP
2	TU14675	SPARK MODULE 24V
3	GA-00803-0	HI-VOLT CABLE
4	TU2372	SNAP BUSHING
5	TU2490	PLUG
6	TU13463	CONTACTOR-24V 9AMP
7	TU13480	TRANSFORMER 200-240V
	TU13515	TRANSFORMER 120V
8	TUD0243	COVER, REAR CTL/BOX
9	TUD0315	PLATE-CONTROL PNL

BONNET ASSEMBLY

PARTS - TUMBLER ASSEMBLY

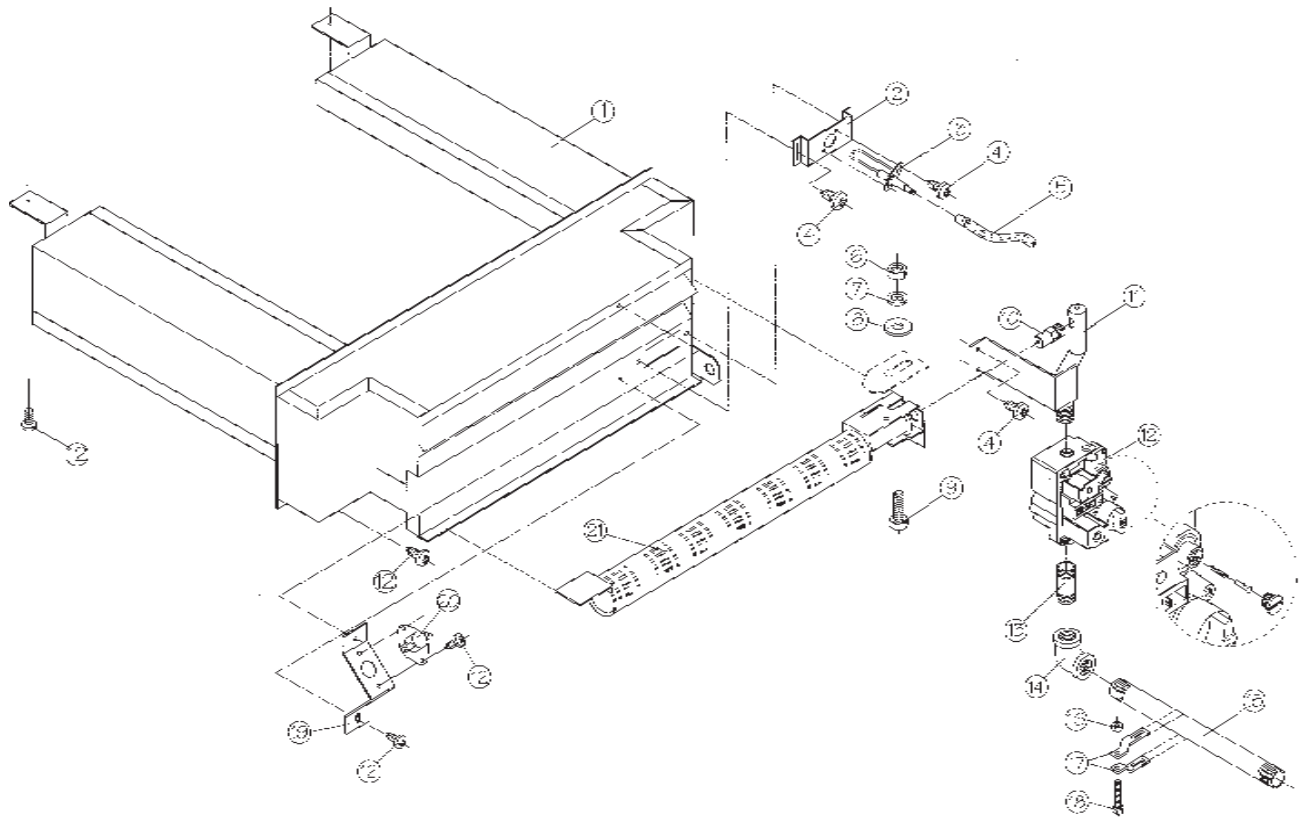

Ref. No.	Part No.	Description
1	TUD0162	BONNET WELDED ASS'Y
2	TUD0242	IGNITOR MOUNTING BRACKET
3	GA-00764-0	IGNITOR ELECTRODE
4	TU7733	SCREW SELF TAP
5	GA-00803-0	HI-VOLTAGE CABLE
6	TU4934	NUT 1/4-20
7	TU2846	LOCK WASHER 1/4
8	TU2847	WASHER 1/4
9	CB36	HEX HD SCREW 1/4-20
10	TU3539	ORIFICE
11	GA-00774-0	PIPE MANIFOLD
12	TU13523	GAS VALVE NG
	TU13513	GAS VALVE LP
13	OP290	NIPPLE PIPE-1/2X2
14	OP291	90 DEG ELBOW
15	390401013	NIPPLE PIPE 1/2-7
16	FB185	NUT #10
17	TU1815	PIPE CLAMP
18	TU3486	BOLT #10
19	TUD0173	HI LIMIT MOUNTING BRKT
20	EA-00243-0	HI-LIMIT THERMOSTAT
21	TU13502	BURNER 50mm